



HOPPER U-II



AZKOYEN Medios de Pago, S.A
Avda. San Silvestre, s/n
31350 Peralta (Navarra) Spain

Tel.: +34 948 709 709
Fax: +34 948 709 709
www.azkoyen.com

Content Index

1. INTRODUCTION	5
2. GENERAL DESCRIPTION.	5
2.1. CAPACITY OF THE HOPPER U-II.	6
2.2. RANGE OF COINS.	6
2.3. DETECTION OF FULL AND EMPTY	6
2.4. DOUBLE COUNTING.	7
2.4.1 Hopper U-II plus ccTalk.	7
2.4.2 Hopper U-II plus parallel.	7
2.5. PAYOUT SPEED	8
2.6. PROTOCOLS	8
2.7. IN-LINE CONFIGURATION.	8
2.8. ANTI-JAM AND ANTI-SPAN SYSTEMS	9
3. TECHNICAL CHARACTERISTICS	10
3.1. POWER SUPPLY.	10
3.2. CURRENT DRAW.	10
3.3. DIMENSIONS.	10
3.4. ELECTRICAL DIAGRAMS AND PIN OUT.	11
3.4.1. - Electrical diagram of the Hopper U-II ccTalk.	11
3.4.2. - Electrical diagram of the Hopper U-II parallel.	11
4. DESCRIPTION OF COMPONENTS	12
4.1. COIN BAY	12
4.2. MOVING FLAP.	13
4.3. COIN LEVEL DETECTORS.	13
4.4. BLADE.	14
4.5. TRIGGER.	15
4.6. CONTROL BOARD.	15
4.6.1. CcTalk control board. Switches and connectors.	15
4.6.2. Parallel Control Board. Jumpers and connectors.	18
4.7. COIN EXTRACTOR DISK	21
4.8. DISK COIN EXTRACTOR MOTOR.	22
4.9. INFRARED PHOTOCELLS FOR COIN COUNTING.	22
4.10. HOPPER BASE	22
4.11. DISK SUPPORT	23
4.12. DISK SUPPORT COVER.	23

4.13. ACCESSORIES.	24
4.13.1. Mechanical supplement to increase the capacity of the hopper.	24
4.13.2.	24
Overflow.	25
4.13.3. Electromechanical scales.	25
5. TOOLS.	26
5.1. TL20 AND HEUS.	26
6. WORKING CONDITIONS AND NORMS.	27
7. CLEANING AND MAINTENANCE	28

Table index

Table 1. Current draw.	10
Table 2. Capacity of the Hopper U-II	12
Table 3. Coin dimensions.	14
Table 4. Pin out connector Tools	16
Table 5. Switches.	17
Table 6. Addresses for switch combinations.	17
Table 7. Working mode for switch combinations.	18
Table 8. Current of the electric motor.	22
Table 9. Capacities of the extensions.	24

Figure index.

Figure 1. Hopper U-II.....	6
Figure 2. Configuration of the Hopper U-II in line.	8
Figure 3. Position of the bases of two Hoppers U-II in line.....	9
Figure 4. Dimensions Hopper U-II	10
Figure 5. Diagram Hopper U-II ccTalk.....	11
Figure 6. Diagram Hopper U-II parallel.....	11
Figure 7. Components of the Hopper U-II.....	12
Figure 8. Types of flaps.....	13
Figure 9. Types of blade.....	14
Figure 10. Control board ccTalk.....	15
Figure 11. Position of the switches.....	16
Figure 12. Parallel Control board.....	18
Figure 13. Pin out Hopper U-II parallel standard.	19
Figure 14. Pin out Hopper U-II parallel with empty detection.	19
Figure 15. Pin out Hopper U-II parallel with full and empty detection.	19
Figura 16. Logic & Working Mode configuration.....	19
Figura 17. Position of the switches.....	20
Figure 18 Types of disk.....	21
Figura 19. Hopper base.....	22
Figura 20. Disk support.	23
Figura 21. Disk support cover.	23
Figura 22. Extensions.	24
Figura 23. Overflow.	25
Figura 24. Electromechanical scales.	25
Figura 25. TL20	26
Figura 26. Cleaning of the Hopper U-II	28

1. INTRODUCTION

This manual contains the technical information on the rotating hoppers in the **Hopper U-II**. The following models are included in this family of products:

- **Hopper U-II ccTalk**
- **Hopper U- II ccTalk encrypted**
- **Hopper U-II ccTalk plus**
- **Hopper U- II ccTalk plus encrypted**
- **Hopper U-II parallel**
- **Hopper U-II parallel plus**

The rotating Hopper U-II is a result of the redesigning process of the traditional Hopper U, obtaining an optimised version of the hopper. This product is 100% compatible with the previous Hopper U model.

This document contains all the characteristics of this new product, concentrating especially on the benefits this hopper provides in comparison to the traditional Hopper U.

2. GENERAL DESCRIPTION.

A *rotating hopper* of the **U- II** series is an intelligent mechanism designed for the return or payout of change of a particular coin type. It works in combination with another intelligent mechanism that governs it and of which it forms part (gaming, vending, parking machines, etc).

These *hoppers* have a **multicoin** extraction system. The multicoin system is defined as a system that allows these *hoppers* to payout **a coin** whose dimensions are between 12 and 32 mm in diameter and 1.2 to 3.5 mm thick.

The product is highly reliable, and has a useful life that guarantees a minimum of 2 million coin extractions.

2.1. CAPACITY OF THE HOPPER U-II.

The quantity of coins that can be stored in the coin bay of the hopper depends on the model. There are 4 different models in the series that provide a range of coin capacities. There is also the possibility to increase their capacity by the use of supplements.



Small hopper

Medium Hopper

Intermediate hopper

Large hopper

L=115mm and **250**
coins

L=154 mm and **400**
coins

L=189 mm and **525**
coins

L=228mm and **600**
coins

**Coins of Ø 24 mm
and thickness 2.8
mm**

**Coins of Ø 24 mm
and thickness 2.8 mm**

**Coins of Ø 24 mm
and thickness 2.8 mm**

**Coins of Ø 24 mm
and thickness 2.8 mm**

Figure 1. Hopper U-II

Consult section "COIN BAY" to see the exact capacities depending on the size of the coin, and also the supplements.

2.2. RANGE OF COINS.

The multicoin extraction system of the hopper U-II, guaranties the payout of coins whose dimensions are between 1.2 and 3.5 mm thick, and 12 to 32 mm in Ø.

Consult section "

COIN EXTRACTOR DISK" for more details.

2.3. DETECTION OF FULL AND EMPTY

The Hopper U-II has detection mechanisms that detect the full and empty levels of the coins in the coin bay.

The detection of empty is done by using an electronic infrared photocell system. (See details in section "**COIN LEVEL DETECTORS**.)

The detection of full is carried out in two different ways:

- Using two infrared photocells that work in the same way as the empty detection photocells. (See details in section "**COIN LEVEL DETECTORS**.)
- Using electromechanical scales. (See details in section "**4.13.3. Electromechanical scales**.").

2.4. DOUBLE COUNTING.

The Hopper U-II has a coin exit control system that provides added protection against attempts of fraud. When the Hopper U-II has this mechanism installed, it is called Hopper U-II plus.

It is a mechanism based on an optic system that controls the movement of the trigger, in a way that the exit of the coin is announced by this mechanism and confirmed by the optic sensor that counts the coins. This mechanism is available for the Hopper U-II parallel, and for the Hopper U-II ccTalk.

2.4.1 Hopper U-II plus ccTalk.

When any anomaly occurs, which could be an attempt at fraud, it will be communicated by the Hopper U-II plus ccTalk as a reply to the ccTalk error command "163 Test Hopper" (See details in the manual "**Protocol ccTalk Hopper U-II**")

It is possible to transform a standard Hopper U-II into a Hopper U-II plus with a kit. Once the kit is installed, it is only necessary to change the position of dipswitch 7 (to ON) so that the standard U-II standard works as a Hopper U-II plus.

2.4.2 Hopper U-II plus parallel.

When any anomaly occurs, which could be an attempt at fraud, it will be communicated by the Hopper U-II plus parallel using the corresponding error commands (see details in the manual "**Protocol parallel Hopper U-II**").

It is possible to transform a standard Hopper U-II into a Hopper U-II plus with a kit. Once the kit is installed, it is only necessary to change the position of dipswitch 7 (to ON), this is explained in "**¡Error! No se encuentra el origen de la referencia.**"

2.5. PAYOUT SPEED

The Hopper U-II pays out up to 8 coins per second. This speed varies with the different disks used. See details in section "

COIN EXTRACTOR DISK".

2.6. PROTOCOLS

The Hopper U-II can work with parallel protocol (parallel) and ccTalk protocol. To see the parallel Hopper U-II protocol, consult the manual "**Parallel Hopper U-II Protocol**"

To see the ccTalk Hopper U-II protocol, consult the manual "**ccTalk Hopper U-II Protocol**"

2.7. IN-LINE CONFIGURATION.

Two hoppers can be configured in line with one another to maximise the use of space.



Figure 2. Configuration of the Hopper U-II in line.

Figure 3 indicates the positions that the bases of the Hopper U-II should be placed to achieve optimum performance of the two hoppers in line.

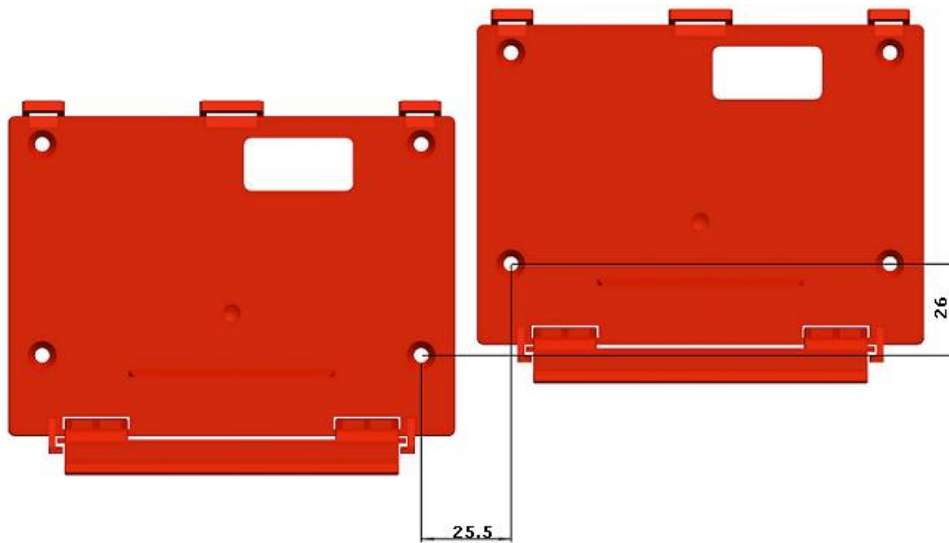

Figure 3. Position of the bases of two Hoppers U-II in line.

2.8. ANTI-JAM AND ANTI-SPAN SYSTEMS

Jam. The hopper has a current draw detector that, when there is a coin jam, reverses the spin direction of the disk motor for 1.5 seconds to free the jammed coins.

Span. The name given to the time between the extraction of two coins. When the hopper detects a time span of more than 5 seconds the hopper reverses the spin direction of the disk motor for 1.5 seconds to move the pile up of coins in the hopper and get them into a position to be extracted.

3. TECHNICAL CHARACTERISTICS

3.1. POWER SUPPLY.

This hopper is capable of working correctly in a range of voltages from **12 V** ($\pm 10\%$) and **24 V** ($\pm 10\%$).

3.2. CURRENT DRAW.

	12Vdc – 24 Vdc ($\pm 10\%$)
Start up current	3 A \pm 20%
Standby current	50 mA \pm 5%
Coin pay out current	450 mA \pm 20%

Table 1. Current draw.

3.3. DIMENSIONS.

Bowl	Length (mm)
Small	119.75
Medium	154
Intermediate	190.3
Large	229.3
Tolerance $\pm 1\text{mm}$	

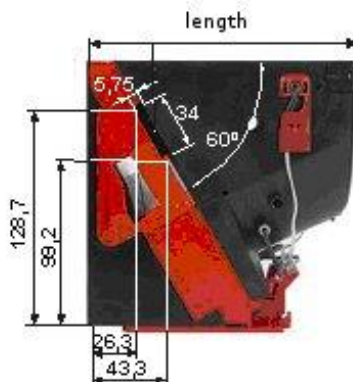

Bowl	Length (mm)
Medium	192.77
Large	229.3
Tolerance $\pm 1\text{mm}$	

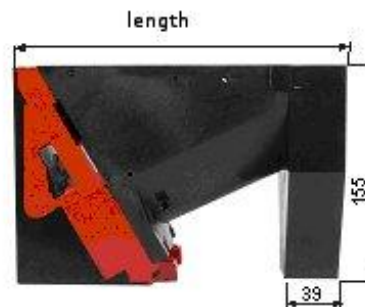

Figure 4. Dimensions Hopper U-II

3.4. ELECTRICAL DIAGRAMS AND PIN OUT.

3.4.1. - Electrical diagram of the Hopper U-II ccTalk.

The following diagram shows the ccTalk driver included in the Hopper U-II.

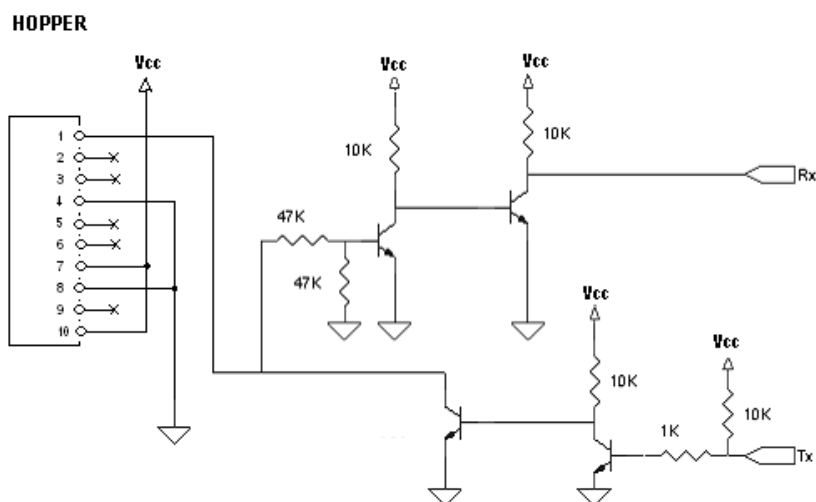

Figure 5. Diagram Hopper U-II ccTalk.

3.4.2. - Electrical diagram of the Hopper U-II parallel.

The following diagram shows the parallel driver included in the Hopper U-II.

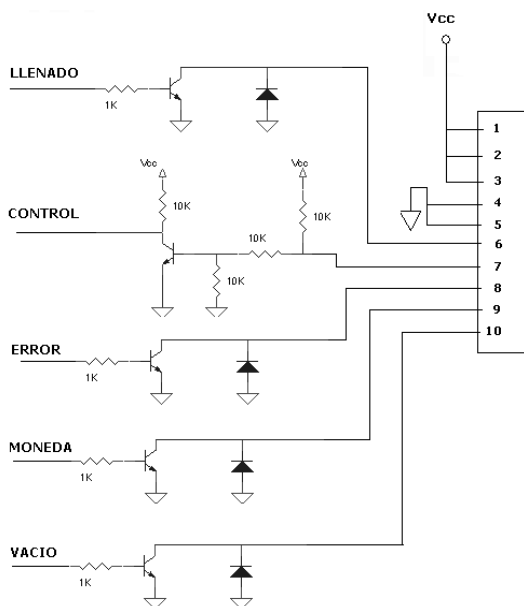
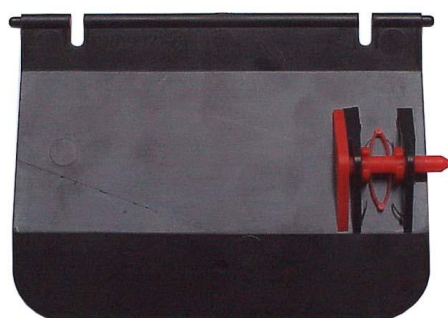

Figure 6. Diagram Hopper U-II parallel.

4.2. MOVING FLAP.

This element moves and doses the flow of coins that move from the coin bay to the extractor disk.

The flap is fixed to the coin bay at the top and the lower part rests on the axis of the disk. This way the spinning disk transmits a rocking motion to the flap that moves the coins in the hopper; this movement moves the coins towards the extraction system. For coins of more than 29 mm in diameter, a different flap is used; it is called the short flap (it allows the bigger coins to pass under the flap to reach the extractor disk). This flap is not recommended for use with smaller coins as it will allow too many coins to reach the disk causing problems with their extraction.



Large flap

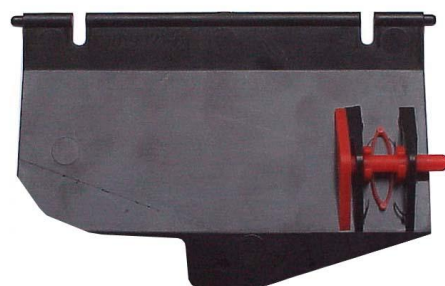

Small flap

Figure 8. Types of flaps

4.3. COIN LEVEL DETECTORS.

The Hopper U-II has full and empty detection sensors.

Empty detection.

Empty detection is carried out by a photocell (photodiode and phototransistor) that is located in the holes at the bottom of the coin bay.

The photodiode emits a beam of light that is detected by the phototransistor when there are no coins in the hopper. When the coin level is lower than the height established for the photocells, the control board detects this and advises the machine.

Full detection.

Full detection, as with the empty detection, is carried out by a photocell (photodiode and phototransistor) that is located in the holes at the top of the coin bay.

The photodiode emits a beam of light that is detected by the phototransistor when the coin level is lower than the photocells. When the coin level is higher lower than the height established for the photocells, the control board detects this and advises the machine.

The application of this system is possible in all the hopper models.

4.4. BLADE.

The function of this element is to slice between the coin and the disk making the coin leave the hopper. The *hoppers* can have two types of blade:



Figure 9. Types of blade

Both models have a metallic reinforcement which is held on the blade with a screw.

	Thickness accepted	Diameter accepted	Cavities in the disk
Long blade*	1.7mm - 3.2mm	22mm - 32mm	7
		18mm - 30mm	8
Short blade	1.7mm - 3.2mm	12mm - 20mm	12
Modified short blade	1.2mm - 1.7mm	12mm - 20mm	12

* To use the hopper with thinner coins please contact the Aftersales Dept. of Azkoyen.

Table 3. Coin dimensions.

4.5. TRIGGER.

In the coin extraction process this device compresses the trigger spring and at a certain point it shoots the coin out of the hopper.

The Hopper U-II has only one type of trigger, whereas previous models had two. It is made of plastic.

4.6. CONTROL BOARD.

This element governs the *hopper* and communicates with the machine. The wiring looms that correspond to the counting, filling and emptying functions and motor are connected to it. There are different models depending on the protocol used (ccTalk or parallel) and its operation with Azkoyen tools.

4.6.1. CcTalk control board. Switches and connectors.

There is only one model of the board for all the Hoppers U-II ccTalk.

The following figure shows the use of each one of the connectors and switches located on the control board.

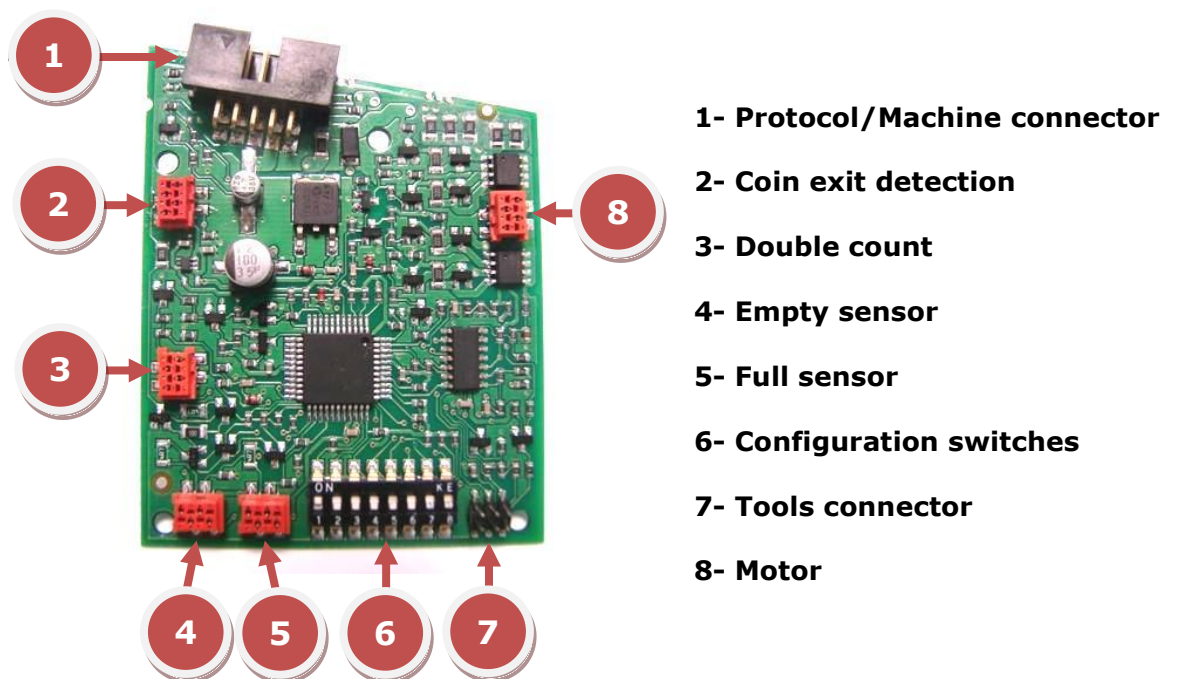

Figure 10. Control board ccTalk

Connectors.

Connector ccTalk:

This connector is used for communication with the machine, which is ccTalk. It is a 10-pin connector.

The pin out of the connector is the following:

Pin 1- Data

Pins 7 and 10 - Power

Pins 4 and 8 - Ground

Connector 6 pins.

This connector is used for communication with Azkoyen programming tools. (See chapter "TL20 AND HEUS.)

The pin out is the following:

Pin	Function
1	-
2	GND
3	RX
4	-
5	TX
6	+5V

Table 4. Pin out connector Tools

This connector is not operative in the hoppers U-II for Italy.

Switches

The configuration of the address of the Hopper U-II, as with other functions, is done with the *dip switches*, 8 switches located on the board which is accessible from the underside of the hopper as shown in the illustration.

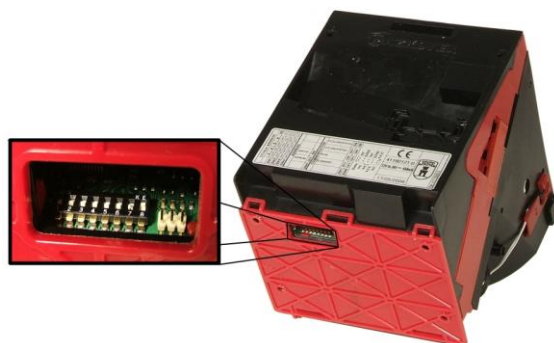

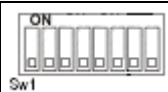
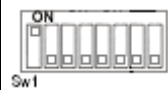

Figure 11. Position of the switches

The function of the switches is shown in the following tables.

SW1	SW2	SW3	SW4	SW5	SW6	SW7	SW8
Selection of the address of the Hopper				Not used	Selection of the address mode	Selection of the working mode	

Table 5. Switches.

- With the switches 1, 2, 3 and 4 up to 16 Hoppers U-II can be addressed, as indicated in the following table:

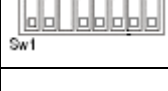
	ccTalk address	SW1	SW2	SW3	SW4
	3	OFF	OFF	OFF	OFF
	4	ON	OFF	OFF	OFF
	5	OFF	ON	OFF	OFF
	6	ON	ON	OFF	OFF
	7	OFF	OFF	ON	OFF

	18	ON	ON	ON	ON

Table 6. Addresses for switch combinations.

- Switch 5 is not used.
- Switch 6 is used to select the address of the hopper U-II; the address can be selected by using the switches or by the address saved in the memory of the hopper (which can be modified using ccTalk commands).
- Switches 7 and 8 are used to select the working mode of the Hopper U-II as shown in the following table:

WORKING MODE	SW7	SW8
STANDARD	OFF	OFF
STANDARD ENCRYPTED	OFF	ON
PLUS	ON	OFF
PLUS ENCRYPTED	ON	ON

Table 7. Working mode for switch combinations.

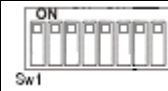
4.6.2. Parallel Control Board. Jumpers and connectors.

There is only one model of board for all the Parallel Hopper U-II.

The function of each one of the connectors and jumpers on the control board are shown in the following figure.

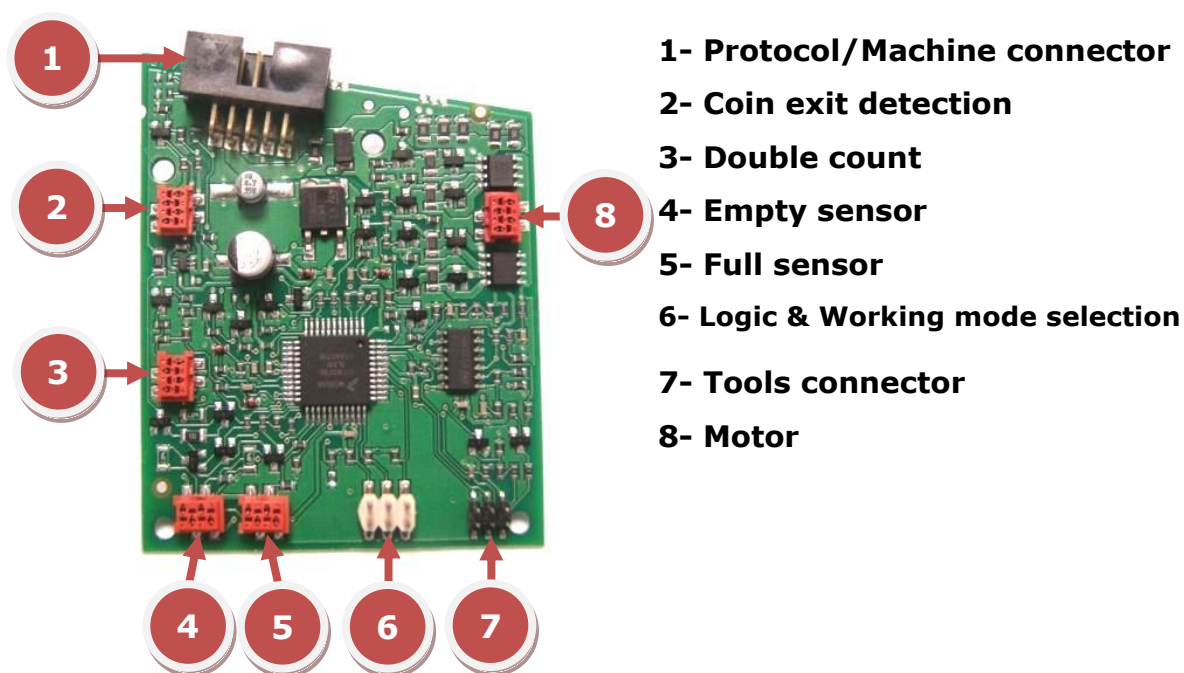

Figure 12. Parallel Control board

Connector for communication with the machine (Parallel protocol).

The Hopper U-II uses a connector of 10 pins (2x5) of 2.5mm, series Molex 8624 or similar, for communication with the machine.

The pin out of this connector depends on the function of the Hopper:

Pin	Function
1,2,3	Vdc
4,5,6	GND
7	Control
8	Error
9	Coin

Figure 13. Pin out Hopper U-II parallel standard.

Pin	Function
1,2,3	Vdc
4,5,6	GND
7	Control
8	Error
9	Coin
10	Empty

Figure 14. Pin out Hopper U-II parallel with empty detection.

Pin	Function
1,2,3	Vdc
4,5	GND
6	Full
7	Control
8	Error
9	Coin
10	Empty

Figure 15. Pin out Hopper U-II parallel with full and empty detection.

Connector for configuration of the Parallel logic & working Mode.

Using connector 6 in figure 16 you can configure the logic, related to the signal levels and the working mode for the Hopper UII

	NEGATIVE	POSITIVE	PULSES
STANDARD			
PLUS			

Figura 16. Logic & Working Mode configuration

See the "Parallel protocol Manual" for further information.

Connector for communication with Azkoyen tools.

This connector is used to carry out communication with the Azkoyen tools. (See chapter "TL20 AND HEUS."). It is a 6-pin connector with the following pin out:

Pin	Function
1	-
2	GND
3	RX
4	-
5	TX
6	+5V

Figura 17. Position of the switches

4.7. COIN EXTRACTOR DISK

The disk picks up the coins in the coin bay and carries them to a position to be ejected from the hopper. The cogs on the outside of the disk mesh with the reduction gear, which makes it spin.

It has ridges to hold the coins and drag from the bottom of the coin bay to top where they are ejected by the trigger.

The disk has pivots that are used to move the coins in the coin bay. The knob on the disk moves the flap.

There are three different coin *extractor disks*. The three accept the same thickness coins which are between 1.2 mm minimum and 3.5 mm maximum.

Disk with 8 ridges and a red pivot: for coins with diameters between 18 and 30 mm. This disk can reach a payout speed of 5.3 coins/second.

Disk with 12 ridges and a yellow pivot: for coins with diameters between 12 and 20 mm. This disk can reach a payout speed of 8 coins/second.

Disk with 7 ridges and a black pivot: for coins with diameters between 20 and 32 mm. This disk can reach a payout speed of 4.6 coins/second.

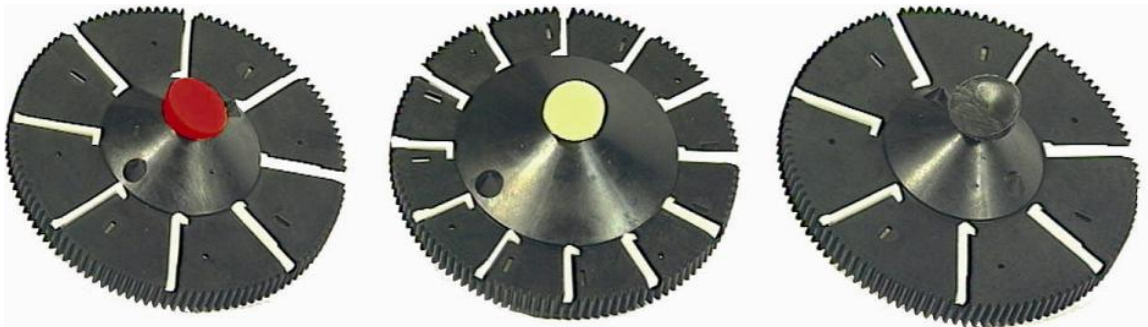

Figure 18 Types of disk.

4.8. DISK COIN EXTRACTOR MOTOR.

This element spins the disk for the extraction of coins from the coin bay.

The Hopper U-II uses a motor of 12 V that be powered from 12V to 24V ($\pm 10\%$).

Its electrical characteristics are:

Current	12 Vdc
Start up	3 A $\pm 20\%$
Spinning	350 mA $\pm 20\%$

Table 8. Current of the electric motor.

4.9. INFRARED PHOTOCELLS FOR COIN COUNTING.

On leaving the hopper, the coin cuts through an infrared beam generated by these photocells. The pulse is considered correct when it is at least 18 milliseconds long.

If the pulse exceeds one second, it is considered as an error and the hopper is placed out of order.

4.10. HOPPER BASE

This is an accessory of the hopper that is used to *attach the hopper to* the machine. It has holes for its fixture to the machine and with clips for holding the hopper.

The Hopper U-II has a new version of base that much improves the fixture of the hopper.



ref.: 11036721

Figura 19. Hopper base.

4.11. DISK SUPPORT

The disk support assembly holds the coin extraction components that make up the extraction system and the control board. It has been designed so that the fixture of all these elements is quick and simple, and incorporated the reduction gear for transmitting movement to the disk and the extraction trigger that ejects the coins from the hopper.

The disk, the blade and reduction gear support is fitted in one side and the motor and the control board on the other.



Figura 20. Disk support.

4.12. DISK SUPPORT COVER.

This element covers and protects the different elements that are installed on the front of the hopper. It has been modified so that it covers the components completely to prevent external intervention.

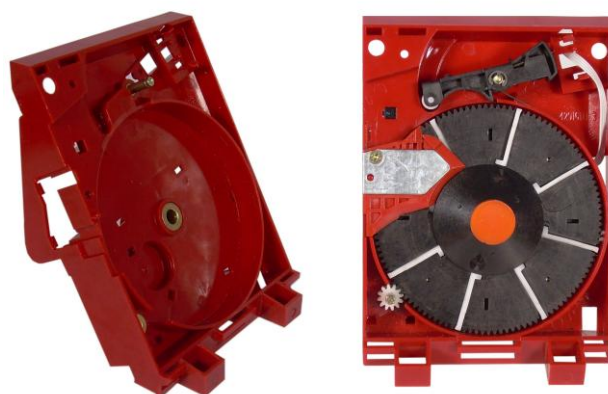

Figura 21. Disk support cover.

This element also has guides for the attachment of a second hopper in installations where the hoppers are placed "in line".

4.13. ACCESSORIES.

4.13.1. Mechanical supplement to increase the capacity of the hopper.

This element is an accessory of the *hopper* that increases its capacity. There are different models and sizes for each of the different types of hopper.

Hopper	Capacity for coins from Ø 24 mm and 2.8 mm thick			
	Capacity of the hopper without extension	Type of extension	Capacity of the extension	Total capacity
Medium	400	Height 80 mm	300	700
Large	600	Height 80 mm	500	1 100
Extra	600	Height 105 mm	1000	1 600

Table 9. Capacities of the extensions.



Figura 22. Extensions.

4.13.2.

Overflow.

A mechanical system that is based on the overflow of the coins from the hopper through gravity.



Figura 23. Overflow.

4.13.3. Electromechanical scales.

A detection system to detect if the Hopper U-II is full that is based on the weight control of the hopper with coins. When the weight of the coins in the coin bay goes above a set weight, which is adjustable with a screw, a micro switch is activated. The *scales* are an accessory of the hopper that are installed under the base of the hopper.



Figura 24. Electromechanical scales.

The electromechanical scales can be installed with all the Hopper U-II models.

5. TOOLS.

The Hopper U-II uses a microcontroller with flash memory that allows the updating of the software using ccTalk commands and the use of the Azkoyen tools.

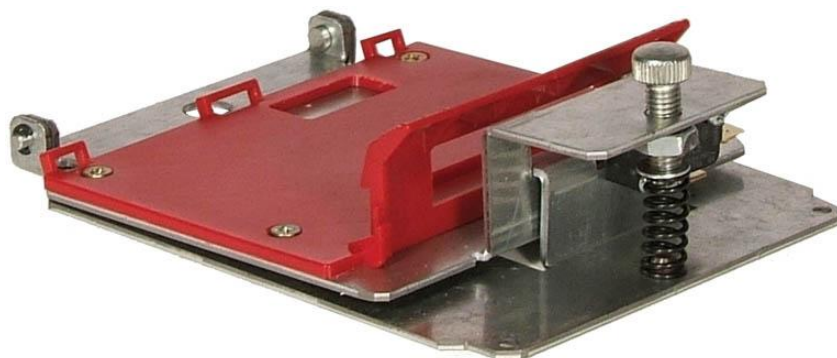
5.1. TL20 AND HEUS.

The TL20 is a programming device for Azkoyen Payment systems' products that allows coin programming, updates, firmware etc. in coin validators and also the firmware of the new Hopper U-II.

It is an easy tool to use that should be used together with the HEUS software.



Figura 25. TL20

The operation of these devices can be summed up in the following points:

- The user should upload the firmware of the Hopper U-II for updating from the PC to the TL20, using the HEUS software. This software can be obtained from Azkoyen from the website or via email.
- Following the instructions for the use of the TL20, connect the Hopper U-II with a 6-pin cable and upload the new firmware to the hopper.

There is a TL20 and HEUS instruction manual available on the website of Azkoyen that can be consulted for more detailed instructions on the use of these tools.

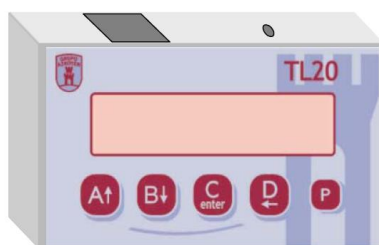
6. WORKING CONDITIONS AND NORMS.

Optimum results from using this equipment can be obtained by meeting the following requirements:

- Power the hopper with a transformer that meets the EN-60742 Norm and provides a maximum of 42.5 Vac without load.
- Install the hopper U-II series with a maximum inclination of +/- 3° on all axes.
- Temperatures:
 - ↘ Storage: from -25 to +70°C.
 - ↘ Working: from +5 to +55°C.
- Humidity: maximum 95% (relative humidity without condensation)
- Norms that are met:
 - ↘ Electromagnetic compatibility:
 - Emission: UNE-EN 61000-6-3:2002
 - Radiation Emission: EN 55011:1999/A1:2000/A2:2003
 - Conductive Emission: EN 55011:1999/A1:2000/A2:2003
 - Immunity: UNE-EN 61000-6-1:2002
 - ESD: UNE-EN 61000-4-2:1997, /A1:1999, /A2:2001, 2004 Erratum
 - Radiation Immunity: UNE-EN 61000-4-3:2003, 2003 Erratum, /A1:2004
 - Peaks and spikes immunity: UNE-EN 61000-4-4:2005
 - Magnetic Field: UNE-EN 61000-4-8:1996, /A1: 2001
 - ↘ Electric Security: EN 60950:2002
 - ↘ Meets the BACTA norm, "Binary Interface V1.0E".
 - ↘ **CE**

Comment: Cable for Rode U-II ccTalk connexion should be shorter than 3 meters.

7. CLEANING AND MAINTENANCE

The maintenance required for the hopper can be summed up as:

- General cleaning of the apparatus after 500,000 coin extractions
- It is recommended to clean the coin exit area where the optic sensors are more frequently. This can be done with cotton wool bud dipped in alcohol.

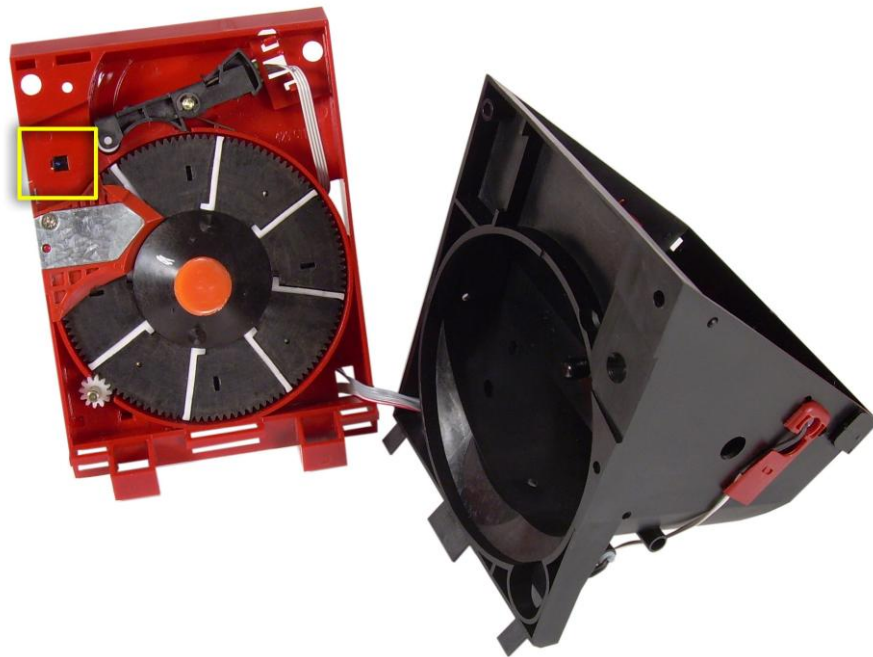

Figura 26. Cleaning of the Hopper U-II

WARNING:

- ✘ Never use products that contain benzene hydrocarbons. These products severely degenerate the plastic parts producing irreparable damage.
- ✘ Never submerge the hopper in any liquid.