

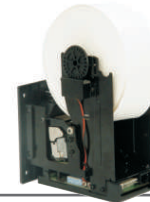

GP58_{series}

Coupon Printer



Installation Guide

Use of Materials Limitations

International Currency Technologies Corporation (ICT) all rights reserved.

All materials contained are the copyrighted property of ICT.

All trademarks, service marks, and trade names are proprietary to ICT.

ICT reserves the right at all times to disclose or to modify any information as ICT deems necessary to satisfy any applicable law, regulation, legal process or governmental request, or to edit, refuse to post or to remove any information or materials, in whole or in part, in ICT's sole discretion.

Contents

1. Introduction.....	2
2. Specifications.....	3
3. Dimension.....	5
3-1. Metal Frame.....	8
3-2. Component Names.....	9
4. Hardware Setup.....	10
4-1. Connection.....	10
4-2. DIP Switch Setup.....	12
4-3. Harness.....	14
4-3-1. I/O Circuit.....	18
4-4. Setup Procedures.....	19
GP-58 CA2/CR.....	19
GP-58III.....	21
5. Software Setup.....	29
5-1. Coupon & Receipt Setup.....	29
5-1-1. GP-58CR Tools	30
5-1-2. GP-58CA2/CR USB Driver Installation.....	56
5-1-3. GP-58III USB Driver Installation.....	60
5-1-4. GP-58 III Tool	60
5-1-5. Graphic Design.....	60
6. How to replace a new paper roll.....	61
6-1. GP-58 CA2/CR.....	61
6-2. GP-58III.....	63
7. Printer Head Guide	65
8. Troubleshooting.....	67

1. Introduction

The GP-58 Series has a built-in real time clock for the ticket time stamping. Its excellent reporting system provides daily and summary transaction reports. The GP-58 Series stores up to 365 days of daily reports, and the reports can be deleted if no longer needed.

Both coupon and receipt are customizable. The downloadable design provides the flexibility to use the customized ticket formats and logos in an easy way. Using the GP-58 Series software tools, the designed format can be saved for later use.

Feature:

- ◆ Full / partial cut function
- ◆ User-friendly multiple interfaces
- ◆ Easy installation and low maintenance
- ◆ Fast printing speed
- ◆ Anti-jam / anti-drag technology (GP58 III)
- ◆ 12V / 24V power consumption available (GP58 III)
- ◆ Support small & large paper rolls (GP58 III)
- ◆ 4G SD card included for large data storage (GP58 III)

2. Specifications

General

Power Source

GP-58 CA2/CR- 12V DC (10.8~13.2 VDC)
Min.165 mA~Max. 3.75A

GP-58III- 12V DC (10.8~13.2 VDC)
Min.140 mA~Max. 6A
24V DC (21.6~26.4 VDC)
Min.90 mA~Max. 3.5A

I/O Level

DC 0V~12V
5mA~130mA

Paper Width

56 ±0.5mm

Paper Roll Diameter

Small Paper Roll Outside Diameter :
65±0.5mm
Large Paper Roll Outside Diameter :
130±0.5mm (only GP-58III)

Power Consumption

GP58CA2/CR- Standby : 0.16 A, 2W
Operation : 2.5A, 30 W
Maximum : 3.75 A, 45 W

GP-58III- Standby : 12V/0.14A, 1.68W
24V/0.1A, 2.4W
Operation : 12V/1.2A, 14.4W
24V/0.6A, 14.4W
Maximum : 12V/6A, 72W
24V/3.5A, 84W

Installation

Indoor

Interface

RS232, USB, Pot of Gold, Pulse

Weight

GP-58 CA2/CR : Approx. 700g

GP-58III : Small Paper Roll Approx. 750g
 Large Paper Roll Approx. 850g
 (without paper roll)

Operation Environment

Operation Temperature : 0°C~+50°C
 Storage Temperature : -20°C~+60°C
 Humidity : 30 %~85 %RH
 (no condensation)

Cutter

Thickness Max. 0.12mm

Life Time Max. 500,000/time

Time Max. 1 sec/time

Print head

Life GP-58 CA2/CR : 30KM
 GP-58III : 50KM

Resolution 8 dots/mm

Speed GP-58 CA2/CR : 40mm/Sec
 GP-58III : 90mm/Sec

3. Dimension

◆ GP-58 CA2/CR

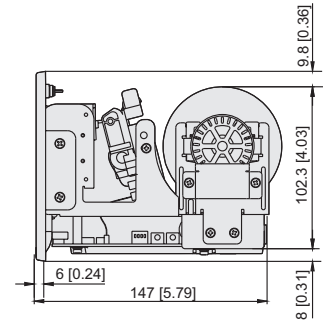
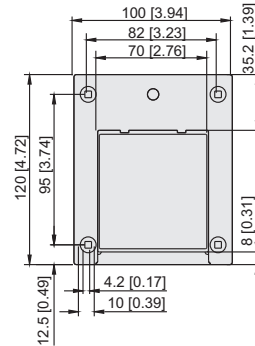
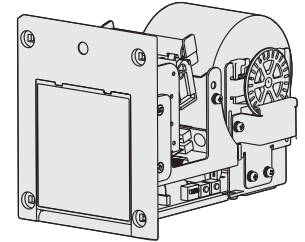
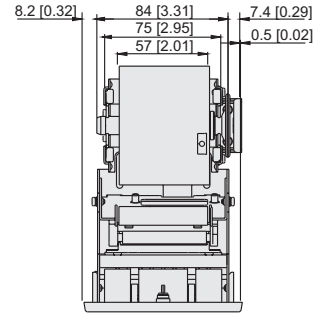

Unit:mm[inch]
 (Figure.1)

◆ GP-58III

Small Paper Roll

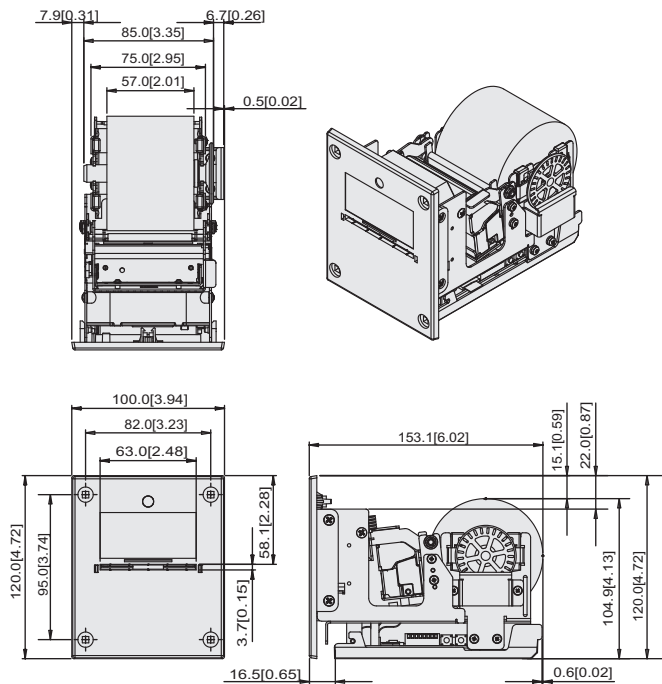

Unit:mm[inch]
(Figure.2)

Large Paper Roll

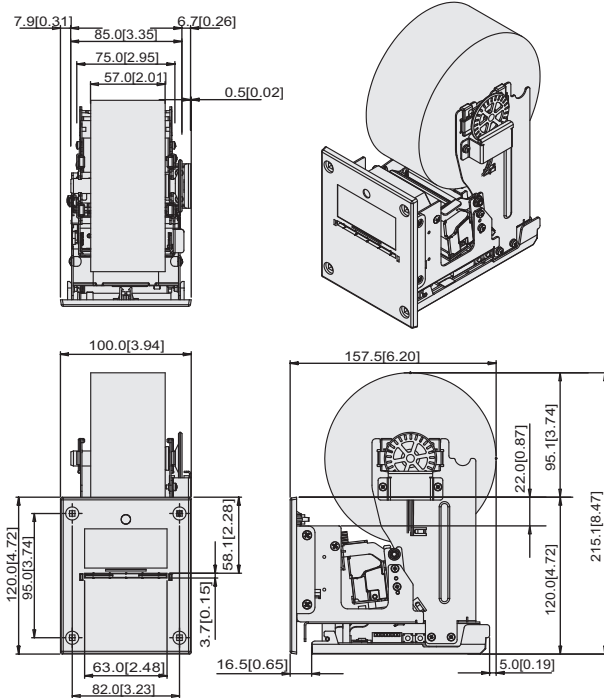

Unit:mm[inch]
(Figure.3)

3-1. Metal Frame (Optional)

For VMC bezel which is larger than GP58 CA2/CR bezel.

Part Number: C19780-R

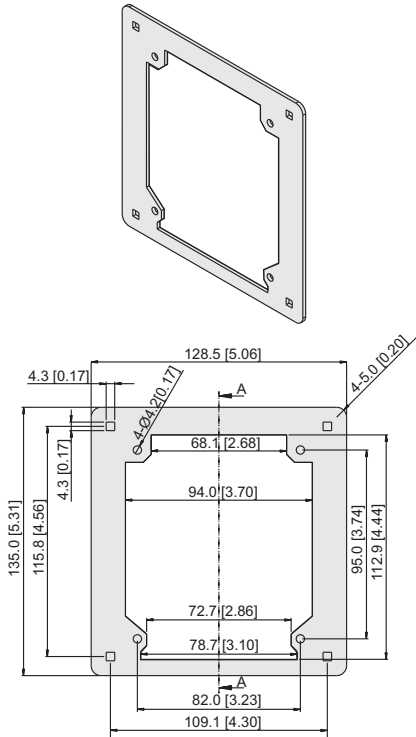

Unit:mm[inch]
(Figure. 4)

3-2. Component Names

◆ GP-58 CA2/CR

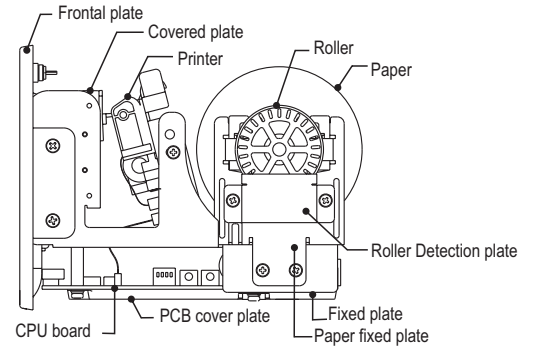

(Figure. 5)

◆ GP-58III

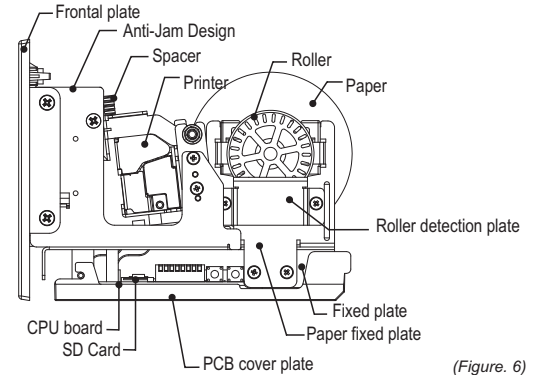

(Figure. 6)

4. Hardware Setup

4-1. Connection

GP-58 CA2/CR

Please refer to the pictures and tables on the following pages for information about the function of each of the connector pins.

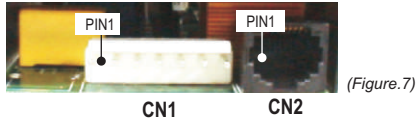

CN1 C/A & B/A

PIN 1- Red.....	+12V DC
PIN 2- Black.....	GND
PIN 3- Brown.....	Coin in signal, Input, Open Collect
PIN 4- Orange.....	Note in signal. Input, Open Collect
PIN 5- Yellow.....	Payout Trigger, Input, Open Collect
PIN 6- Green.....	Ticket Out, Output, Open Collect
PIN 7- Blue.....	Error output, Output, Open Collect

CN2 Serial Interface

PIN 1- GND
PIN 2- TXD2, Output, TTL Level.
PIN 3- RXD2, Input, TTL Level.
PIN 4- PROGRAM
PIN 5- /RESET
PIN 6- VCC (+5V DC)
PIN 7- RXD1, Input, TTL Level.
PIN 8- TXD1, Output, TTL Level.



Do not use RS232 and USB simultaneity.

GP-58III

Please refer to the pictures and tables on the following pages for information about the function of each of the connector pins.

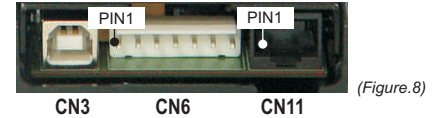

CN6 C/A & B/A

PIN 1- Red.....	+12V DC
PIN 2- Black.....	GND
PIN 3- Brown.....	Coin in signal, Input, Open Collect
PIN 4- Orange.....	Note in signal. Input, Open Collect
PIN 5- Yellow.....	Payout Trigger, Input, Open Collect
PIN 6- Green.....	Ticket Out, Output, Open Collect
PIN 7- Blue.....	Error output, Output, Open Collect

CN3 USB Interface

PIN 1- VCC (+5 DC)
PIN 2- D-
PIN 3- D+
PIN 4- GND

CN11 Serial Interface

PIN 1- NC
PIN 2- NC
PIN 3- NC
PIN 4- POG-RXD1, Input, RS232 Level
PIN 5- VCC (+5V DC)
PIN 6- VCC (+5V DC)
PIN 7- GND
PIN 8- POG-TXD1, Output, RS232 Level



Do not use RS232 and USB simultaneity.

4-2. DIP Switch Setup

GP-58 CA2/CR

Function	SW1	SW2	SW3	SW4	KEY1	KEY2
Part Cut	OFF					
Full Cut	ON					
GP-58 CR Mode		OFF				
GP-58 CU Mode		ON				
Default			OFF			
Pulse Mode				OFF		
Pot of Gold Mode				ON		
*Print Transaction Records					ON	
*Paper Forward						ON

* KEY1 & KEY2 only work when SW4 is OFF (Pulse Mode).

(Table.1)

GP-58III

Function	SW1	SW2	SW3	SW4	SW5	SW6	SW7	SW8
POG print interval: 1 sec	OFF	OFF						
POG print interval: 3 sec	ON	OFF						
POG print interval: 5 sec	OFF	ON						
POG print interval: 7 sec	ON	ON						
Normal Mode			OFF					
Low Paper Roll Detection Mode (1)			ON					
Pulse Normal High (2)				OFF				
Pulse Normal Low (2)				ON				
Pulse Mode					OFF	OFF		
Pot of Gold Mode					OFF	ON		
Hopper Mode					ON	OFF		
Reserved					ON	ON		
Reserved							OFF	
							ON	
Operation Mode								OFF
Download by USB								ON

(Table.2)

- ◆ KEY 1 + SW3 OFF: Paper Transaction Records
KEY 1 + SW3 ON : Low Paper Roll Detection Setting, press one time to increase 1mm.
- ◆ KEY 2 + SW3 OFF: Paper Forward and Cut
KEY 2 + SW3 ON : Low Paper Roll Detection Setting, press one time to increase 1mm.

(1) Low Paper Roll Detection Mode:

- After adjusting diameter of Low Paper Roll Detection, please reset GP58III.
- Range of Low Paper Roll Detection diameter is 21~39 mm.
- The paper roll's diameter cannot be set 29, 31,33,35, 37, 40 mm.

(2) Hopper Mode

4-3. Harness

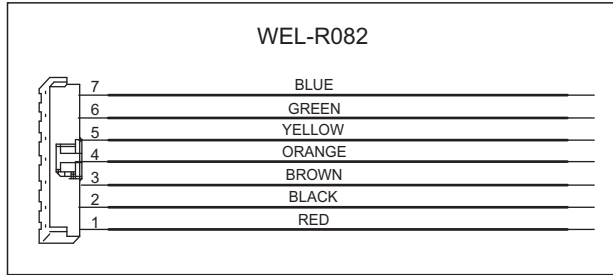

(Figure.9)

PIN	Color	Function	Signal
1	Red	Power +12V	POWER+ INPUT
2	Black	Power -0V (GND)	POWER- INPUT
3	Brown	COIN_IN Trigger	PULSE INPUT
4	Orange	NOTE_IN Trigger	PULSE INPUT
5	Yellow	PAYOUT Trigger	PULSE INPUT
6	Green	TICKET_OUT	LOW VOLTAGE OUTPUT
7	Blue	ERROR_OUT	LOW VOLTAGE OUTPUT

(Table.3)



- PIN3~PIN5 Normal Input Voltage: HI DC 5V~12V.
Trigger Level Voltage: Low 0V (GND) Output Current Max. 5mA.
- PIN6~PIN7 Normal Floating.
Output Signal: Low 0V (GND) Input Current Max. 130mA.

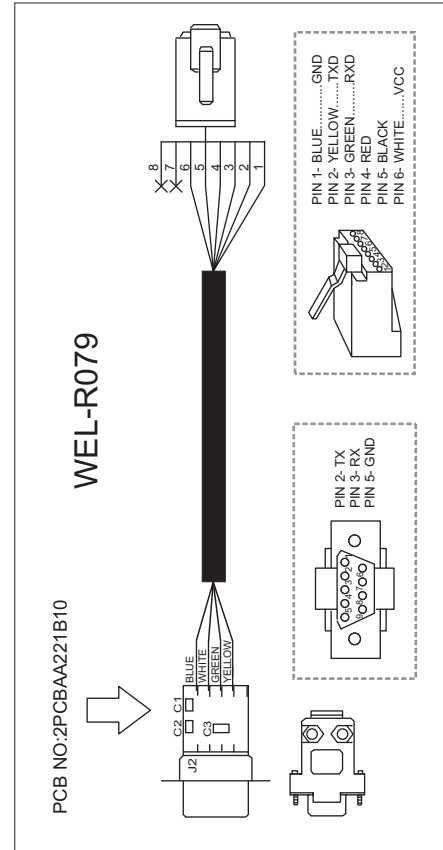

(Figure.10)

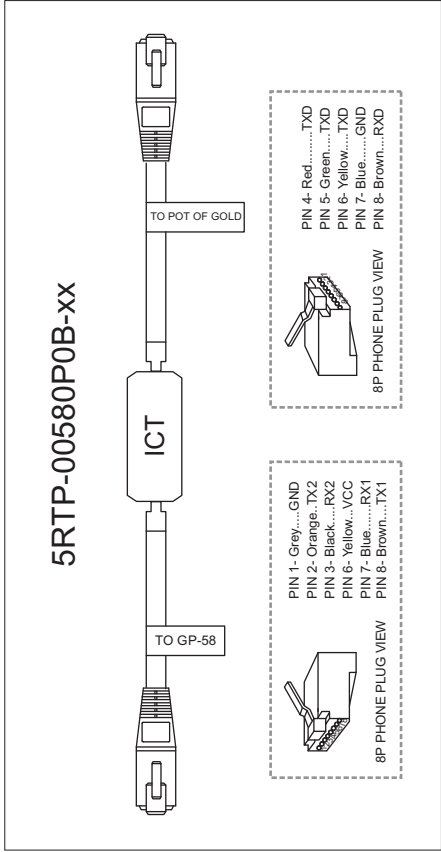

(Figure. 11)

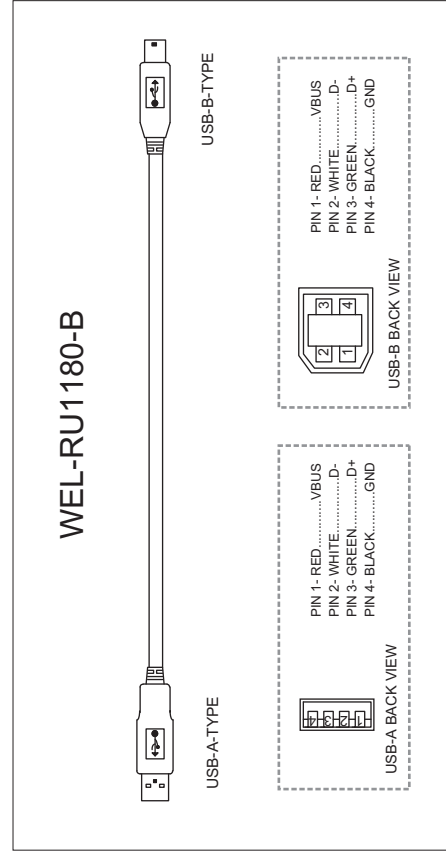

(Figure. 12)

4-3-1. I/O Circuit

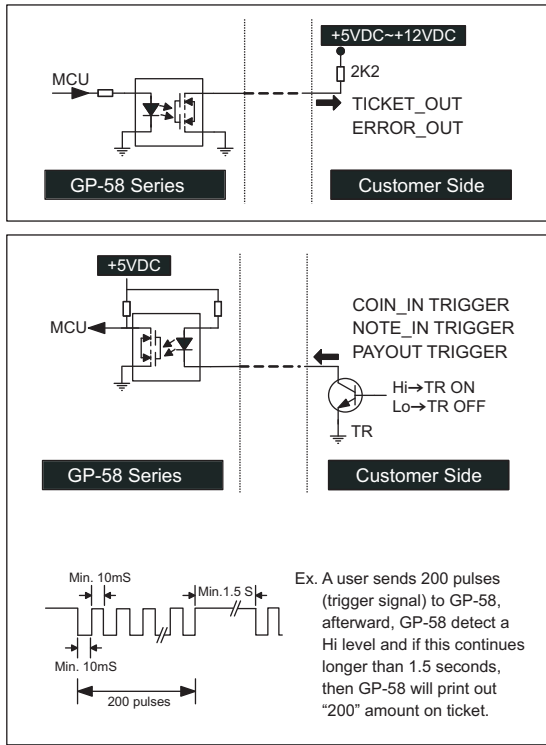

(Figure. 13)

4-4. Setup Procedures

GP-58 CA2/CR

General Setup:

Step 1. Connect WEL-R082 to CN1 on PCB.

Step 2. Install paper roll into paper roll container on machine, paper roll is required to be setup according to the same direction of raster. (Please refer to Chapter 6.)

Step 3. **For RS-232 or Coupon/ Receipt Format Setup:**

Connect WEL-R079 to PC COM port and CN2 on machine. (Page 15, Figure. 10)

Step 4. Turn power on and install paper roll properly, the machine will automatically detect the paper (Approx. 2 seconds) and roll the paper into the printing module. If the installation of the paper roll is correct, the machine is ready for printing. Working light on the machine's bezel will be on. (Please connect the wires as Page 23, Figure. 14)

Step 5. JP2 is for battery setting.

Switch between enable and disable for battery setting.

*Default setting is Enable. (Page 27, Figure. 18)

Pot of Gold Setup:

- Step 1. Connect WEL-R082 to CN1 on PCB.
- Step 2. Install paper roll into paper roll container on machine, paper roll is required to be setup according to the same direction of raster. (Please refer to Chapter 6.)
- Step 3. Connect 5RTP-00580P0B-xx to VMC and CN2 on machine. (Page 16, Figure 11)
- Step 4. Turn power on and install paper roll properly, the machine will automatically detect the paper (Approx. 2 seconds) and roll the paper into the printing module. If the installation of the paper roll is correct, the machine is ready for printing. Working light on the machine's bezel will be on. (Page 24, Figure. 15)
- Step 5. JP2 is for battery setting.
Switch between enable and disable for battery setting.
*Default setting is Enable. (Page 27, Figure. 18)

GP-58III

General Setup:

- Step 1. Connect WEL-R082 to CN6 on PCB.
- Step 2. Install paper roll into paper roll container on machine, paper roll is required to be setup according to the same direction of raster. (Please refer to Chapter 6.)
- Step 3. **For USB or Coupon/ Receipt Format Setup:**
Connect WEL-RU1180-B to PC COM port and CN3 on machine. (Page 17, Figure. 12)
Then please insert the SD Card (The 4G SD Card is included with GP-58III)
- Step 4. Turn power on and install paper roll properly, the machine will automatically detect the paper (Approx. 2 seconds) and roll the paper into the printing module. If the installation of the paper roll is correct, the machine is ready for printing. Working light on the machine's bezel will be on. (Please connect the wires as Page 25, Figure. 16)
- Step 5. SW1 is for battery setting.
Switch between enable and disable for battery setting.
*Default setting is Disable. (Page 28, Figure. 19)

Pot of Gold Setup:

- Step 1. Connect WEL-R082 to CN6 on PCB.
- Step 2. Install paper roll into paper roll container on machine, paper roll is required to be setup according to the same direction of raster. (Please refer to Chapter 6.)
- Step 3. Connect RJ45 to RJ45 wire to VMC and CN11 on machine. (Please connect the wires as Page.26, Figure 17)
- Step 4. Turn power on and install paper roll properly; the machine will automatically detect the paper (Approx. 2 seconds) and roll the paper into the printing module. If the installation of the paper roll is correct, the machine is ready for printing. Working light on the machine's bezel will be on. (Page 26, Figure. 17)
- Step 5. SW1 is for battery setting. Switch between enable and disable for battery setting. *Default setting is Disable. (Page 28, Figure. 19)

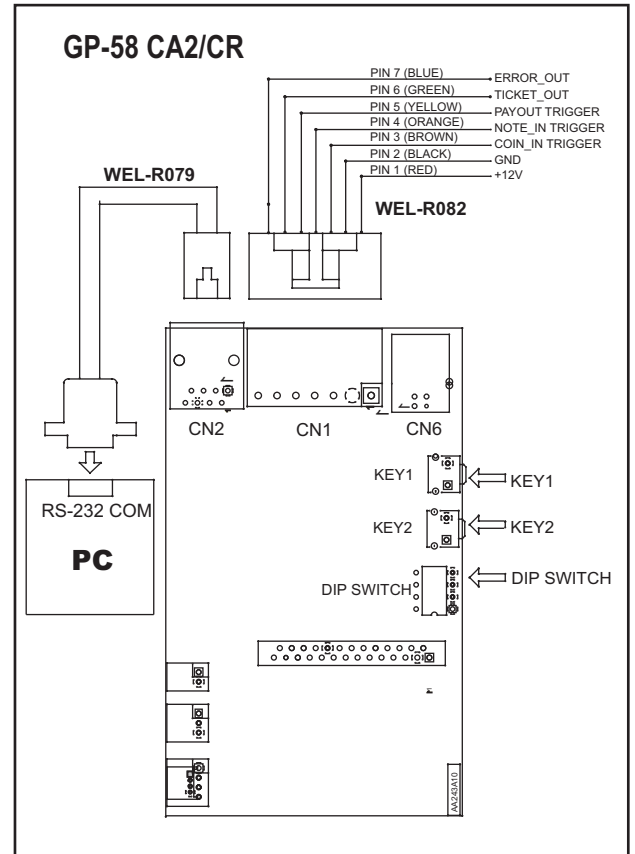

(Figure. 14)

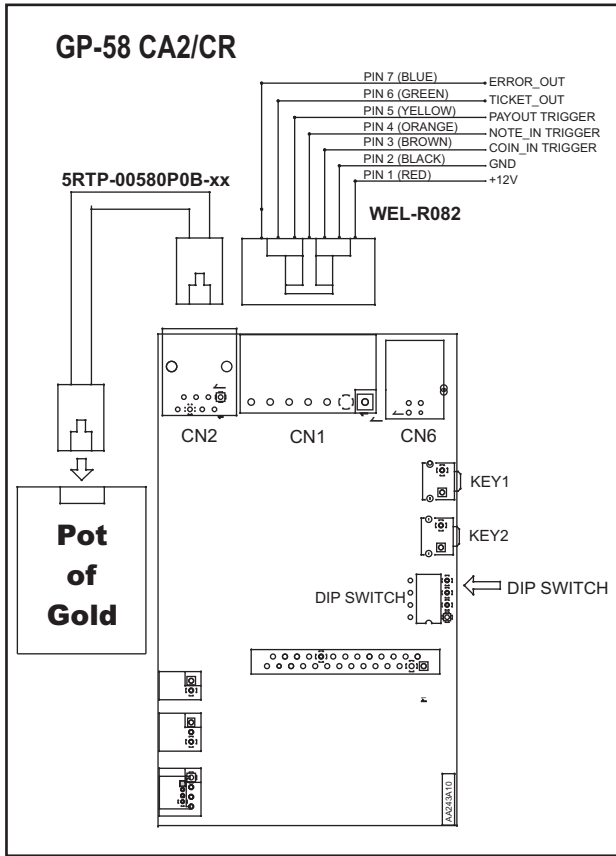

(Figure.15)

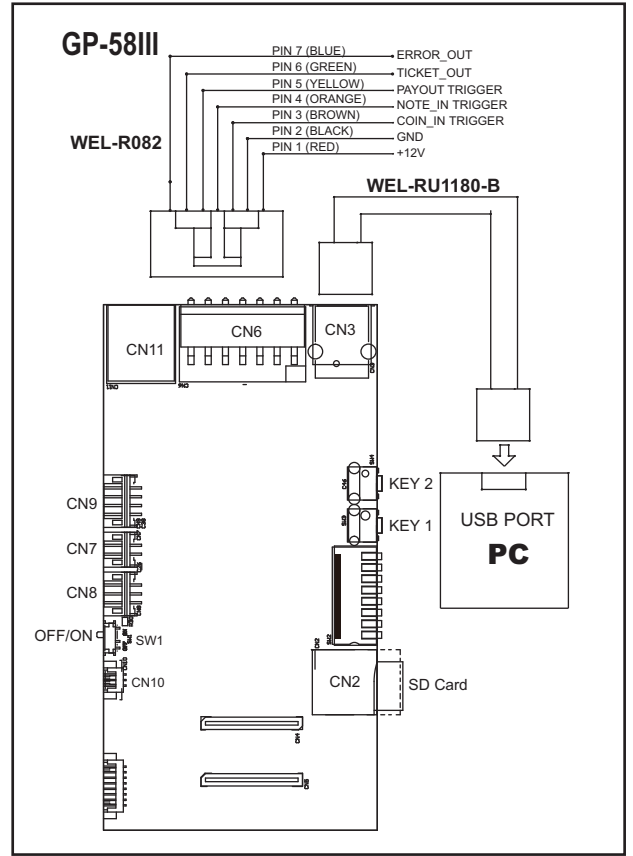

(Figure.16)

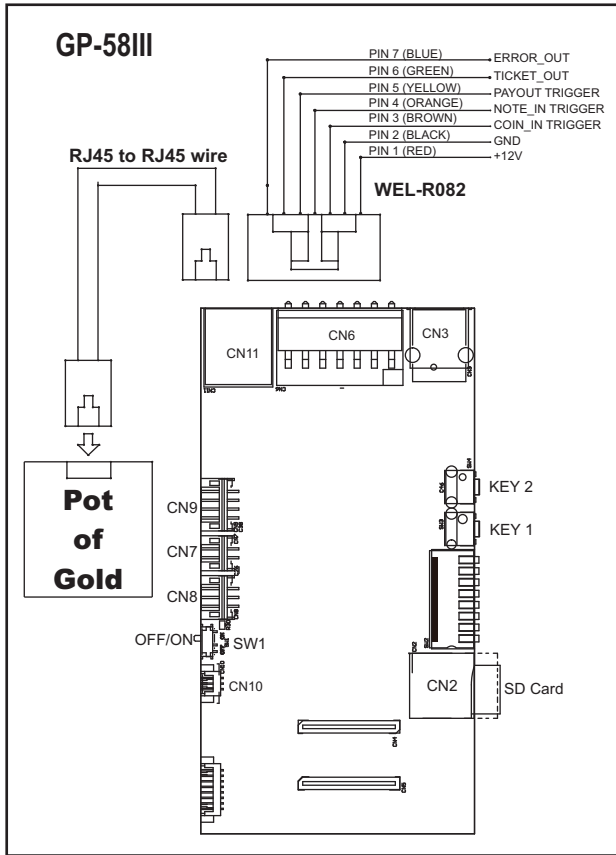

(Figure.17)

GP-58 CA2/CR

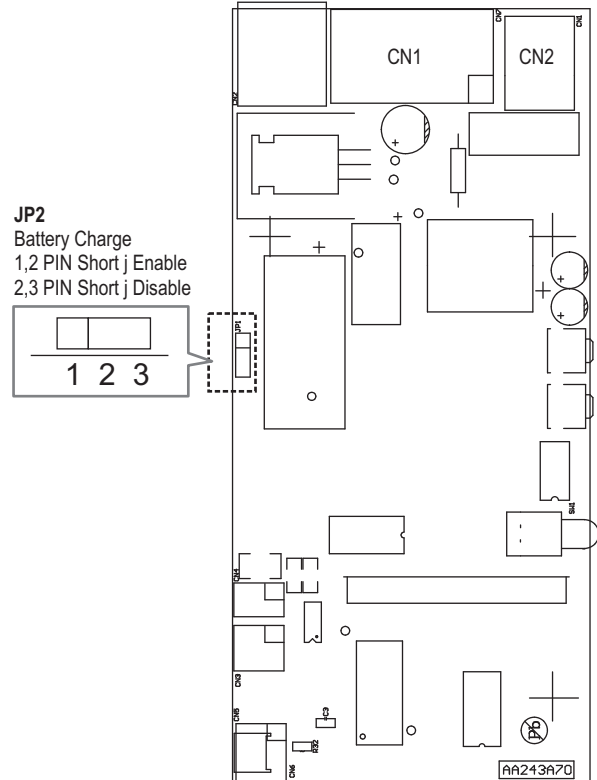

(Figure.18)

GP-58III

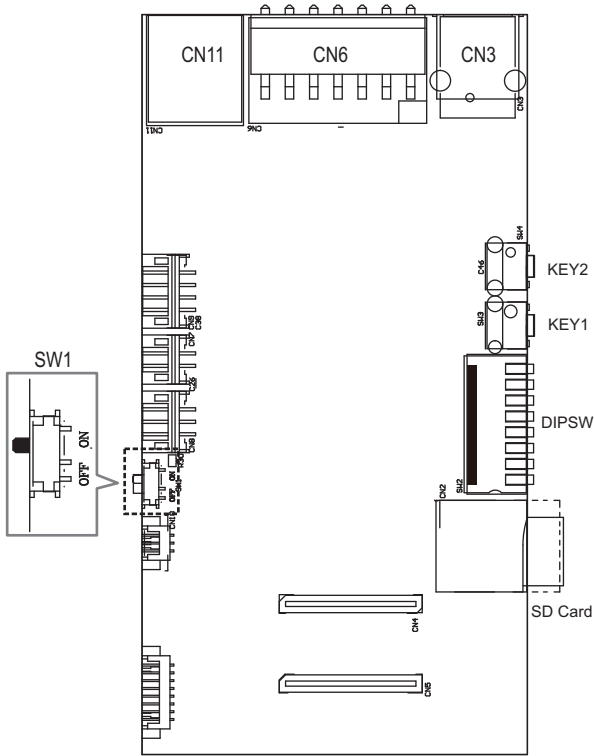

(Figure.19)

5. Software Setup

5-1. Coupon & Receipt Setup

The GP-58CA2/CR can print two different types of tickets, each for a different purpose:

A coupon indicates the payout points for the player.

A receipt is provided to the player when s/he inserts coins or bills into the C/A or B/A.

The format of the coupon and receipt can be designed and changed by yourself and then upload it into machine by using GP-58CR Tools utility.

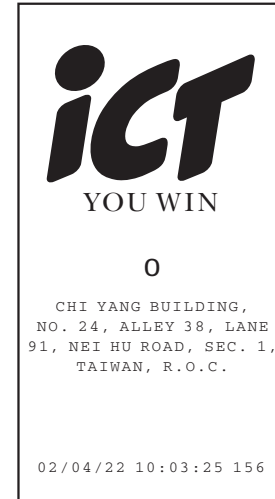

(Figure.20)

5-1-1. GP-58CR Tools

Installation

Please insert the CD into the CD-ROM drive and then choose the right model. The setup program will guide you through the installation process.

Please insert the CD after printer installation, there will be a new program at setup up menu.

Due to GP-58CA2/CR tool parallels with GP-58CR tool, users can refer to following examples of GP-58CR tool to operate GP-58CA2/CR.

Execute the GP-58CR utility

Double-click on the GP-58CR icon to execute GP-58CR utility.

NOTE:

GP-58CA2/CR is a combination of GP-58CR and new USB interface, so the tool only works at GP-58CR mode. For USB, please use GP-58CA2/CR tool and driver.



Do not plug RS232 and USB simultaneity.

1. To install GP-58CR Tools (RS-232 English Version), please follow the operation as below.

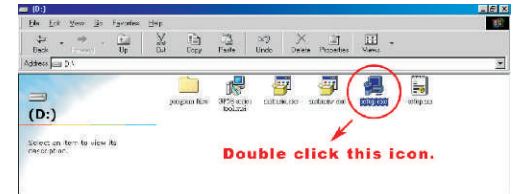

(Figure.21)

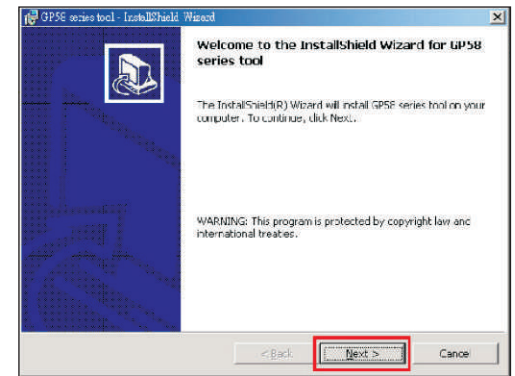

(Figure.22)



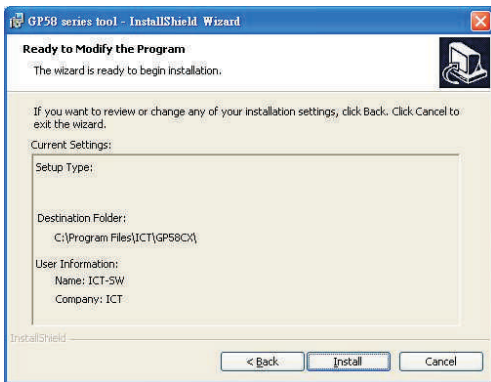

(Figure.23)

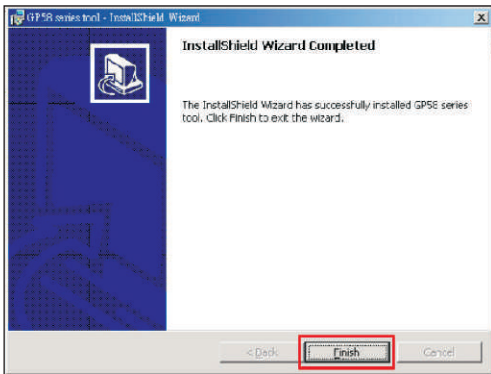

(Figure.24)



To install GP-58 CR Tool (USB English Version), please follow the operation as below:

1. Insert CD select the right model, then click [INSTALL USB TOOL].



(Figure.25)

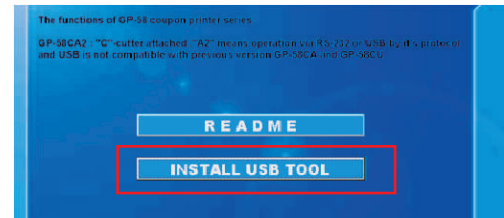

(Figure.26)



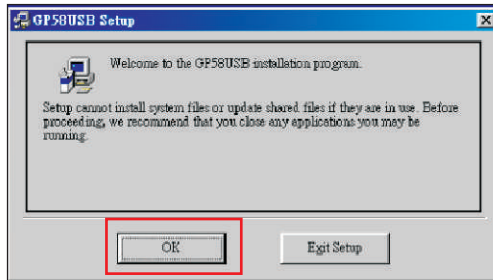

(Figure.27)

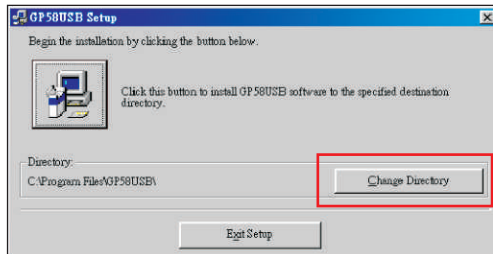

(Figure.28)



(Figure.29)

Due to GP-58CA2/CR tool parallels with GP-58CR tool, users can refer to following examples of GP-58CR tool to operate GP-58CA2/CR or refer to [GP-58CA2/CR README software element] item in driver.

◆ The screen will be displayed as below.

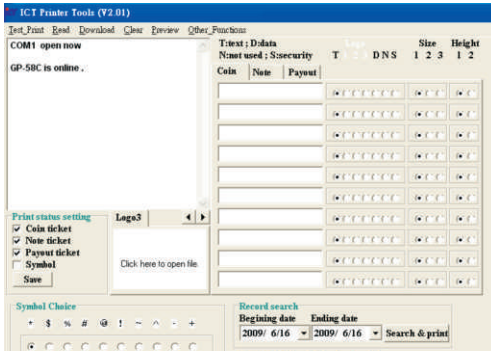

(Figure.30)

◆ This is the Message Display Window.

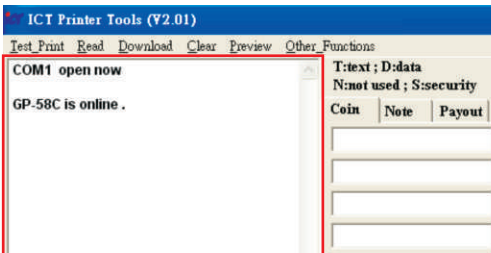

(Figure.31)

◆ Cancel: Cancel the download from PC to GP-58CR.
(Must reset GP-58CR afterward)

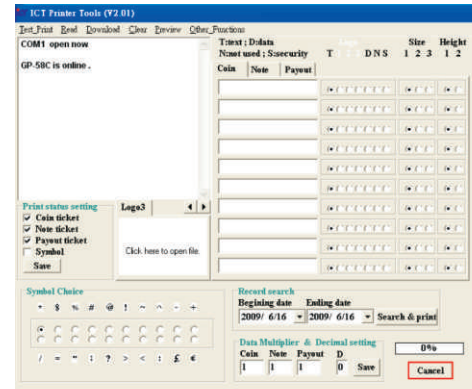

(Figure.32)

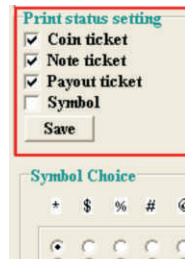

(Figure.33)

◆ Select the working functions of GP-58CR.

- e.g. 1. If you only select "Print coin ticket", it will not print out any ticket except the coin ticket.
2. If you select the "symbol" option, there will be 2 symbols on both sides of the data number.
3. Click "save" button to save print status to GP-58CR.

- ◆ Select the symbols.

Original fonts.

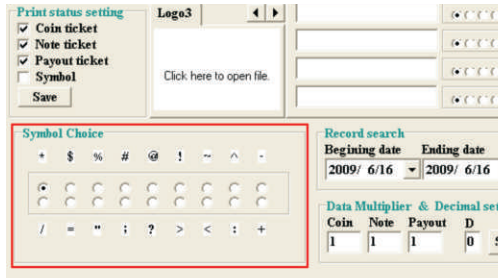

(Figure.34)

Fonts increased.



(Figure.35)

- ◆ To choose the logo you want to use (Logo1, Logo2 or Logo3), click on "Click here to open file". A sub-window of the file selection is going to be displayed. You can choose a bitmap file as the logo.

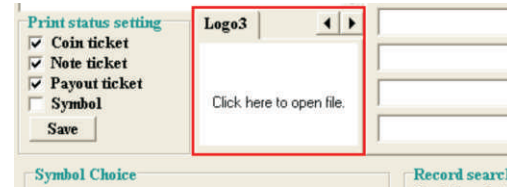

(Figure.36)

- ◆ Input the text from line 1 to line 10 to display on tickets .

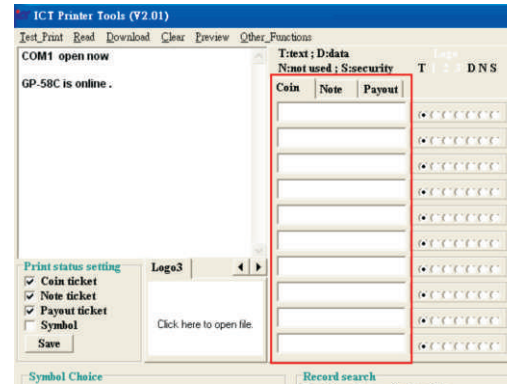

(Figure.37)

- ◆ There are three word sizes: size 1: " 8x13" pixels, size 2: "14x24" pixels, and size 3: "22x36" pixels.

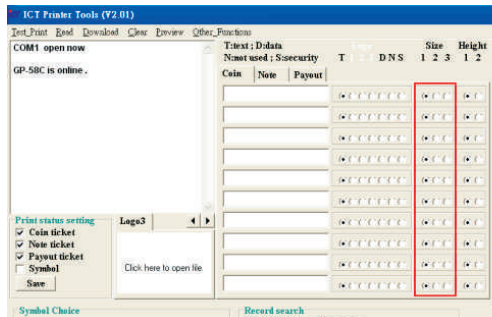

(Figure.38)

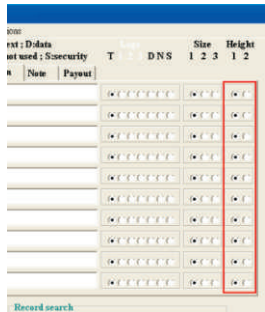

- ◆ The setting is for the heights of the words. In GP-58CR system, "Height 1" is default.

(Figure.39)

- ◆ Arrange contents detail for every line.

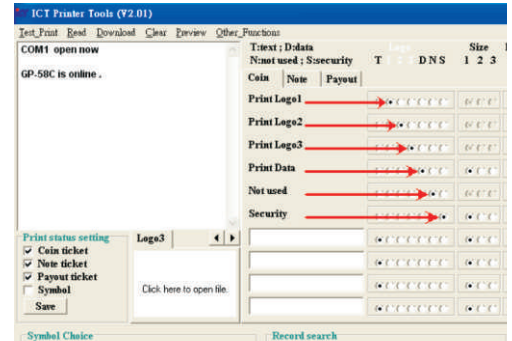

(Figure.40)

- ◆ Set the printer to print out the record of a certain period.

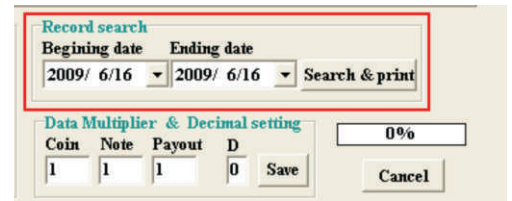

(Figure.41)

- ◆ Coin: Setup the multiplier of each pulse from C/A.
Note: Setup the multiplier of each pulse from B/A.
Payout: Setup the multiplier of each pulse of Payout signal.
D: Setup a decimal point (it can't exceed three digits).

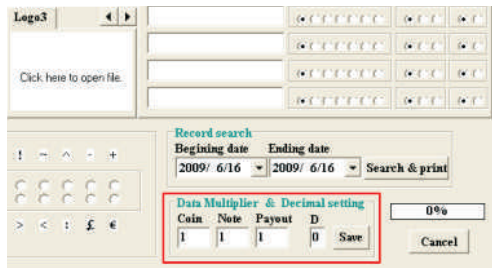

(Figure.42)

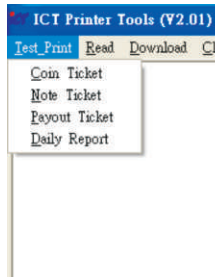

(Figure.43)

- ◆ Coin Ticket: Print a Coin coupon.
- Note Ticket : Print a Note coupon.
- Payout Ticket: Print a Payout coupon.
- Daily Report: Print a daily report.

- ◆ Firmware Version :
Read and display the current firmware version of the printer.

Date & Time :
Read and display the current date and Time of the printer.

Data Multiplier & Floating-pointing :
Read and display the current rate of each pulse.

Print Status :
Read and display the "print status setting".

Summary Report :
Read and display the current total records.

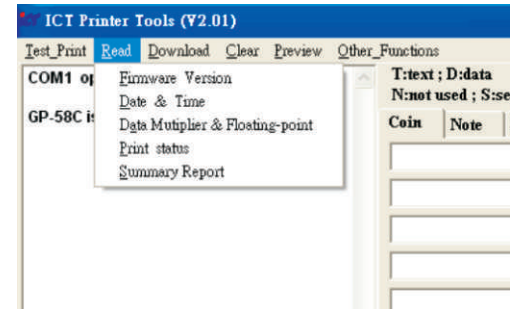

(Figure.44)

- ◆ All Formats : Download current designed ticket format to printer.
- Coin Ticket Format : Download coin ticket format to printer.
- Note Ticket Format : Download note ticket format to printer.
- Payout Ticket Format : Download payout ticket format to printer.
- Logo 1 : Download Logo 1 to printer.
- Logo 2 : Download Logo 2 to printer.
- Logo 3 : Download Logo 3 to printer.
- Date & Time : Download date and time in computer's system to printer.
- Date Format : (1) YY/MM/DD: Year / Month / Day
 (2) DD/MM/YY: Day / Month / Year
 (3) MM/DD/YY: Month / Day / Year
 (4) YY/DD/MM: Year / Day / Month

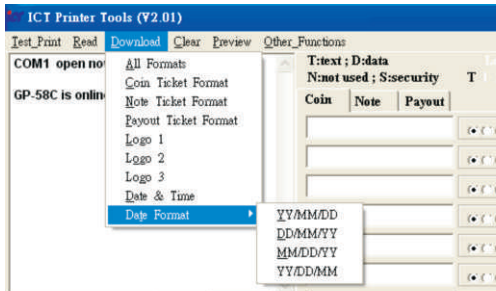

(Figure.45)

- ◆ Clear : Choose one of the options on the list to clear.

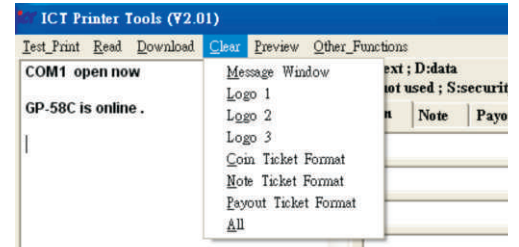

(Figure.46)

- ◆ Preview: Preview contents of coin ticket, note ticket or payout ticket.

**Note: The symbols will not be shown at front/back of the ticket in preview mode.*

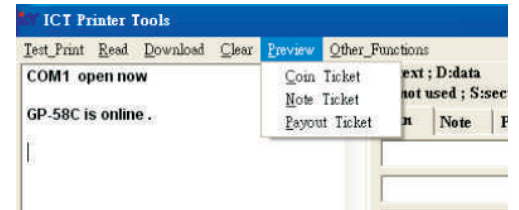

(Figure.47)

◆ Cutter Test : (1) Full cut (2) Part Cut.

Erase Record : Erase the summary record from printer.

Save Ticket Format : Save designed ticket.

Load Ticket Format : Load designed ticket format.

Print History Report : Print all daily history reports.

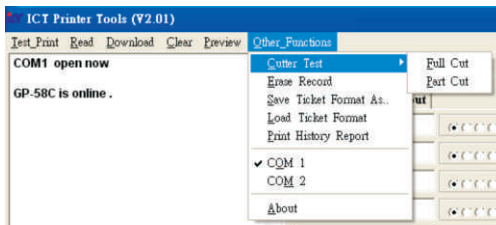

(Figure.48)

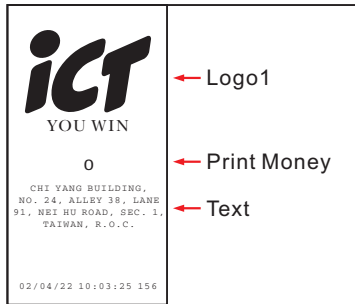

(Figure.49)



1. Start program "Paint".

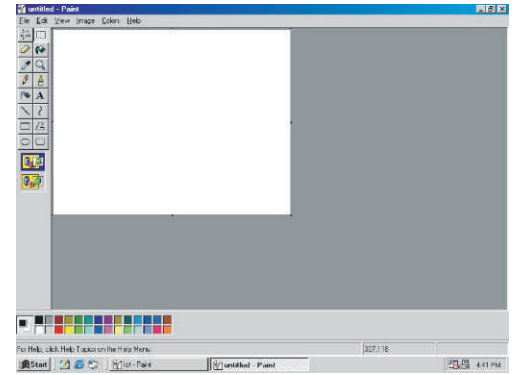

(Figure.50)



- The value of width is fixed at 384 pixels and can not be changed. However, the figure's height is not fixed, it can be changed by users.

NOTE:

The size of the graphic file can not be over 16K bytes.

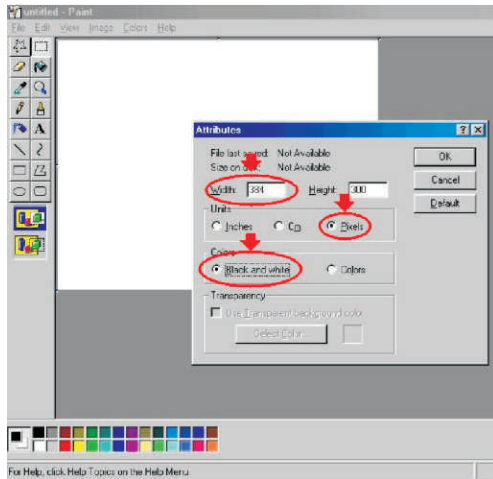

(Figure.51)



- Draw "ICT" image.

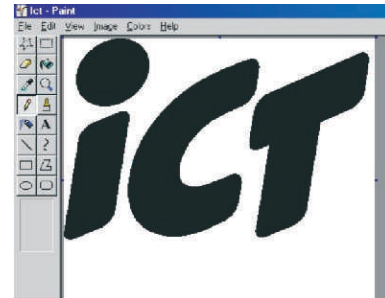

(Figure.52)



- Key in "YOU WIN".



(Figure.53)



5. Save file.

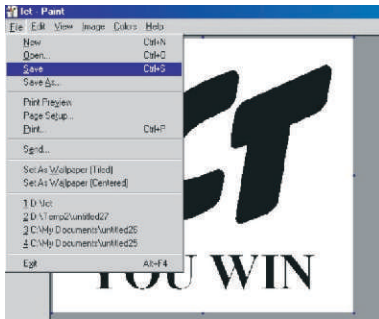

(Figure.54)

6. Save as type " Monochrome Bitmap (*.bmp, *.dib)".

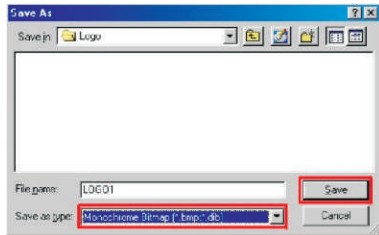

(Figure.55)

7. Click "Yes".

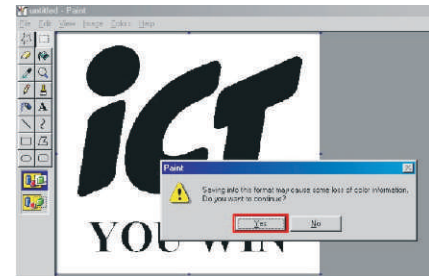

(Figure.56)

8. Click on "click here to open file".

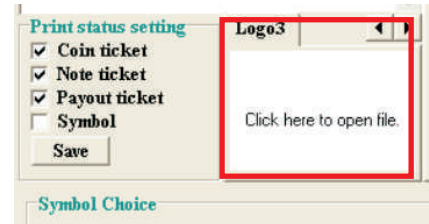

(Figure.57)

9. Open logo file.

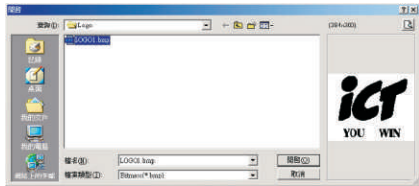

(Figure.58)



10. Save logo 1 to GP-58CR.

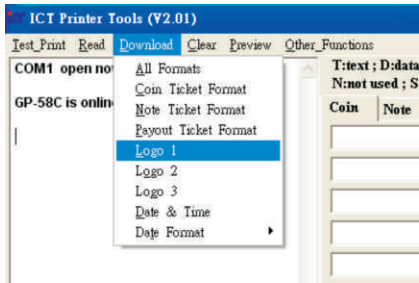

(Figure.59)



11. Key in words and adjust word size/ height.



(Figure.60)



12. Choose logo file to adjust height.

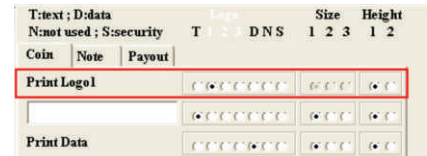

(Figure.61)



13. Download word and logo format from "Coin Ticket Format", 'Note Ticket Format" or Payout Ticket Format".

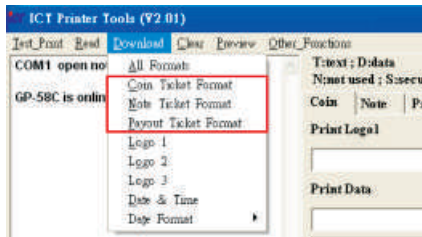

(Figure.62)



14. Printing trial.

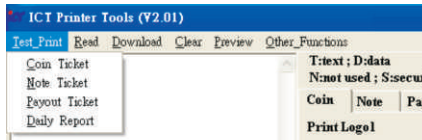

(Figure.63)

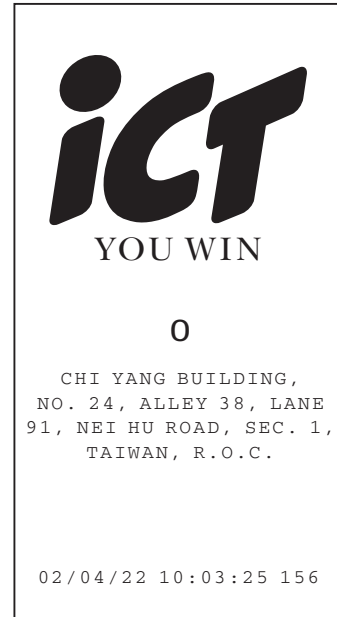

(Figure.64)

5-1-2. GP-58CA2/CR USB Driver Installation

◆ Driver Installation

Before installing GP-58CA2/CR USB driver, please make sure GP-58CA2/CR USB tool is installed.

Please refer to the following step to install driver :

1. Connect GP-58CA2/CR USB to PC, then select "Install from list or specific location".

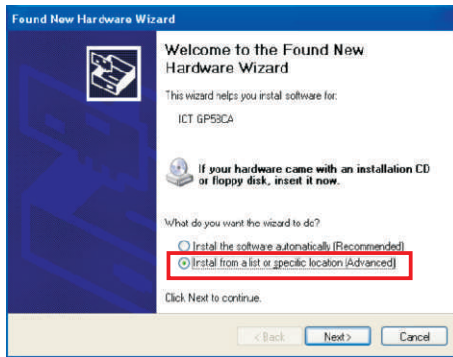

(Figure.65)



2. Browse the directory and search the driver.

Source CD includes two drivers:

XP/2000.....GP58CA2\Driver\winxp

98SE.....GP58CA2\Driver\win98

Select one driver then click "Next>".

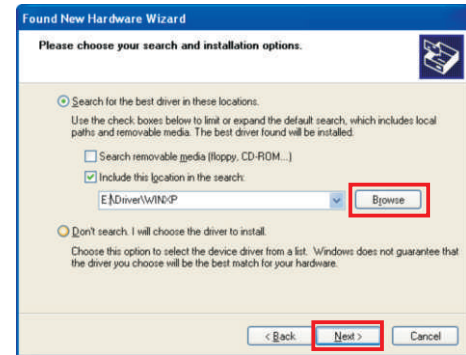

(Figure.66)



3. Start to install.

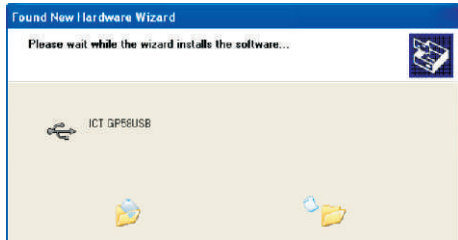

(Figure.67)

4. Click "Continue Anyway".

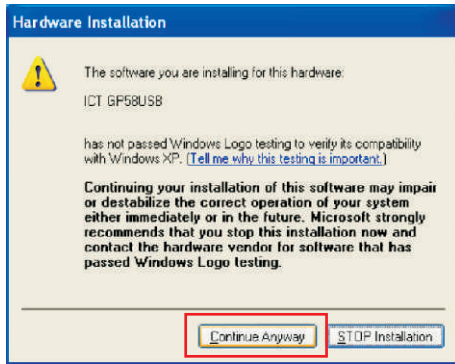

(Figure.68)

5. Install complete.

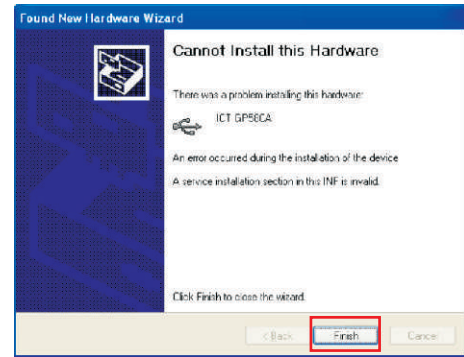

(Figure.69)

6. Check on the device list for installed printer from Device Manager.



(Figure.70)

5-1-3. GP-58 III- USB Driver Installation

5-1-4. GP-58 III Tool

5-1-5. Graphic Design

Please refer to the Read Me file on the CD.



(Figure.71)

6. How to replace a new paper roll?

6-1. GP-58 CA2/CR

1. Insert a new paper roll going clockwise.

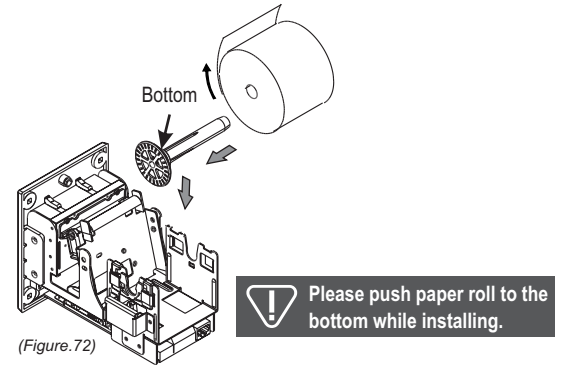

2. Push the printer lever clockwise.

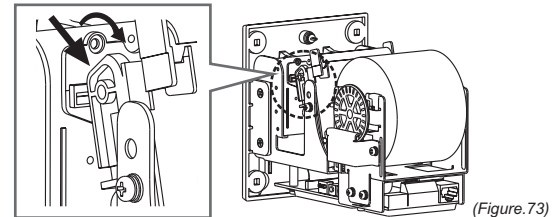

3. When Detector Sensor automatically detect paper, installation completes.

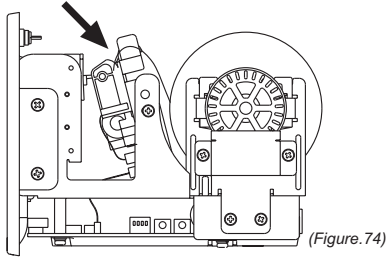

(Figure.74)

4. Push the printer lever back counterclockwise.

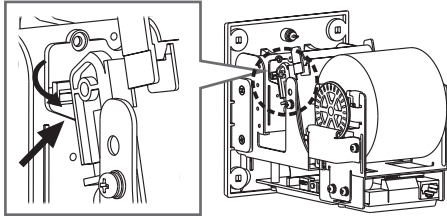

(Figure.75)

<i>Maintenance Notice</i>	
	Recommended Mild, non-abrasive, soap water.
DO NOT USE	Organic solvent , Alcohol, Volatility liquid.

6-2. GP-58III

1. GP-58 III -Small Paper Roller

Insert a new paper roll going clockwise. Insert the paper roll into the feeder. The paper will be fed automatically without opening the printer head.

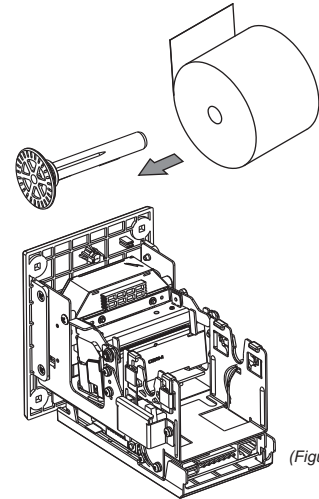

(Figure.76)

2. GP-58 III -Large Paper Roller

Insert a new paper roll going clockwise and place it in the back area temporary. After set the paper into the printer feeder then replace it to the original place.

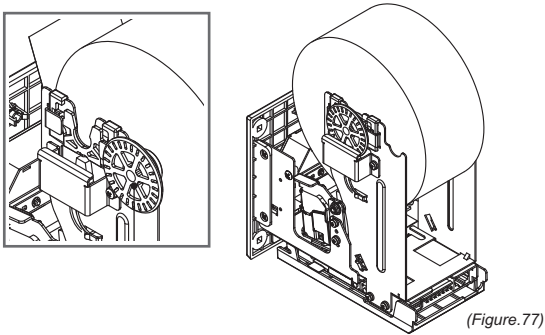

7. Printer Head Guide

GP-58III

- ◆ When you need to reset the printer head please follow the steps below.
- ◆ Printer head DOES NOT need to be removed to exchange a new paper roll. The printer head can detect the paper automatically.

Unlock the Printer Head

- Step 1. Lift the spacer up.
- Step 2. Pull back the white lever.
- Step 3. Lift the movable frame.
- Step 4. Remove the paper roll.

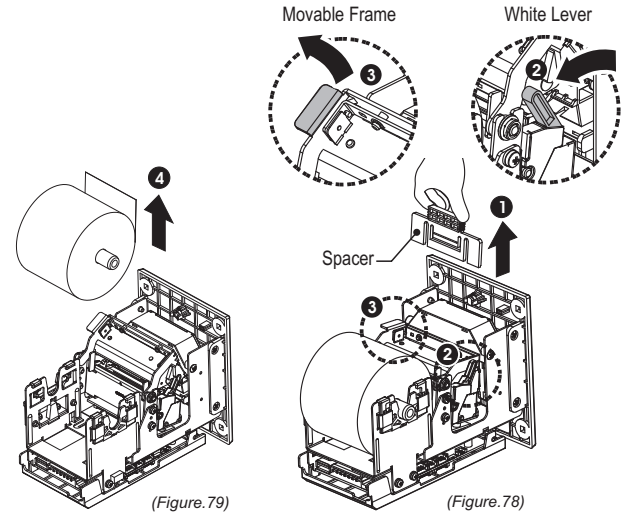

8. Troubleshooting

GP-58III

SW3	LED Flashes	Status
OFF	Red1 time	thermal print feeder out of paper or thermal print doesn't push back.
OFF	Red 2 times	Cutter has not been in position.
OFF	Red 3 times	GP58III is out of paper or raster error.
OFF	Red 4 times	Anti-pulling sensor has foreign subject.
OFF	Flashing Orange	no SD Card.
OFF	Flashing Red	Paper roll diameter lower than setting.
OFF	Flashing Green	Print in progress.
OFF	Green is ON	Normal.
ON	Red 1	indicates ten-digit of paper roll low level.
ON	Green 1	indicates unit digits of paper roll low level.
ON	Orange ON	paper roll low level setting error.

(Table.4)

Lock the Printer Head

- Step 1. Place the printer paper in.
- Step 2. Pull back the white lever FIRST.
- ! Must pull back the White Lever FIRST.**
- Step 3. Push down the movable frame
- Step 4. Push back the movable frame.
- Step 5. Push back the spacer.

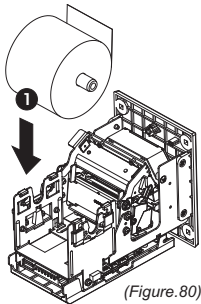

(Figure.80)

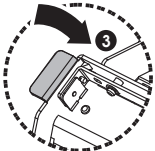

Movable Frame



White Lever

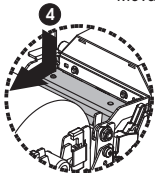

Movable Frame

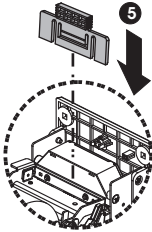

Spacer

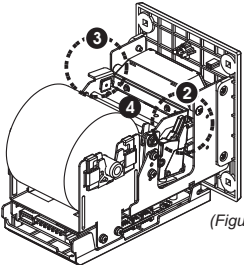

(Figure.81)

! Be sure to push back the movable frame, or the Printer will not function.

! If the error can not be solved after corrective actions or it recurs, please contact ICT for technical support.



International Currency Technologies Corporation

Ji-Hong Building, No 24, Alley 38, Lane 91, Nei-hu Rd., Sec. 1, Taipei, Taiwan, R.O.C.

Tel: 886-2-2797-1238 · Fax: 886-2-2797-1634

sales@ictgroup.com.tw (For Sales) · rma@ictgroup.com.tw (For Customer Service)

Website: www.ictgroup.com.tw